

AI-002 Hot Air Sealing Machine

Operation Manual

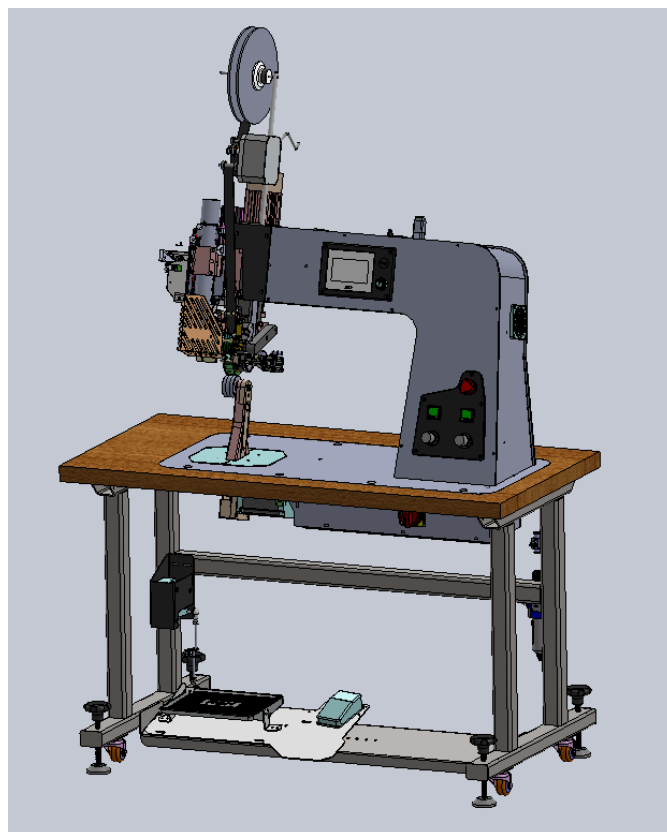

is powered by

H&H Asia Group Limited

e = service@hh.com.hk
t = 852.24813068
f = 852.24813727

Room 1117, 11/F, Asia Trade Centre, 79 Lei Muk Road, Kwai Chung, N.T., Hong Kong

Table of Content

> Precautions Regarding to Safety	3
> Name Plate.....	5
> Introduction.....	6
> Specifications.....	7
> Features	8
> Identification of Components.....	9
>> Front View	9
>> Cutter Assembly	10
>> Heater Positioning Assembly (front).....	10
>> Heater Positioning Assembly (rear)	11
>> Touch Screen Control Panel & Pressure Adjustment Panel	12
> Principle of Seam Sealing	13
> Preparation for Installation	14
> Control Method.....	15
>> Touch Screen Control Panel	15
>> Foot Switch	15
>> Control Menu Navigation	16
>> Pressure Adjustment.....	19
> Start Up and Shut Down Procedures	20
>> Start up Procedures.....	20
>> Shut down Procedures	23
> Basic Operation	24
>> Procedures of Seam Sealing.....	25
>> Tape Cutting.....	25
>> Tape Loading	26
>> Nozzle	27
> Advance Operation	28
>> Personality 1.....	29

>> Advance Mode.....	30
>> Differential Speed.....	31
>> Electronic Nozzle Position Adjustment.....	32
>> Memory	34
>> Individual Program for Start/ Middle/ End of Tape	35
>> Digital Tensioner.....	36
>> Alarm.....	37
> Maintenance.....	38
>> Preventative	38
>> Procedures for Replacing Parts	39
> Trouble Shooting	41
Appendix A . Nozzle Air Flow Cross Reference Table.....	42
Appendix B . Penumatic Scheme	43
Appendix C . Wiring Scheme	44
Appendix D . Tape Start, Tape Middle, Tape End Parameters	45
> Tape Start Program	45
> Tape Middle Program.....	51
> Tape End Program.....	56

> Precautions Regarding to Safety

Please observe these safety tips for a safe, efficient, and injury free operation of your equipment. By strictly following all instructions contained in this manual you will certainly obtain an excellent performance from the use of this equipment for many years.

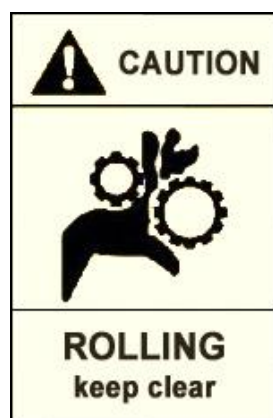
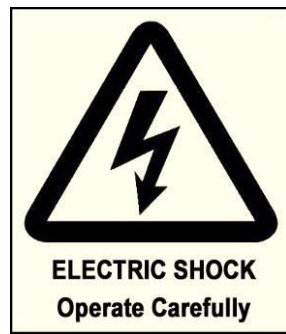

> Precautions Regarding to Safety (cont.)

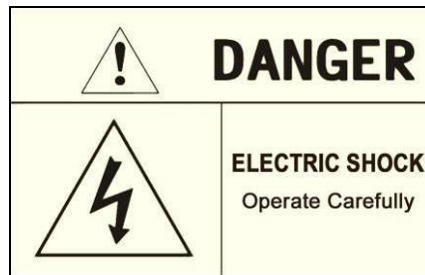

> Name Plate

Model : AI-002

Hot Air Sealing Machine

spec A-NNN				
Voltage	Frequency	Power	Compressed Air	Weight
220 V	50/60 Hz	3600 W	0.4-0.6 Mpa	130 Kg
Date :			S/N :	

H&H Asia Group Ltd.

Room 1117, 11/F, Asia Trade Centre, 79 Lei Muk Road, Kwai Chung, N.T., Hong Kong

Tel : (852) 2481-3068 Fax : (852) 2481-3727

www.hh.com.hk

MADE IN CHINA



> **Introduction**

Thank you for choosing AI-002 hot air sealing machine by H&H.

The hot air sealing machine described in this manual is one of the most sophisticated machines in the market today. Built on pure digital platform and designed for the professional users, AI-002 incorporated many new features that makes seam sealing much easier than before. Operators are recommended to have basic knowledge and skill in seam sealing operation before using this machine.

In order to fully understand how to use this machine properly, and avoid damage to both the machine and operating personnel, please read this manual carefully and keep it safe for future reference.

> Specifications

Model	:	AI-002
Voltage	:	AC 220 V
Frequency	:	50/60 Hz
Power Consumption	:	3600 W
Compressed Air	:	0.4- 0.6 Mpa
Air Consumption	:	100 L/min max
Sealing Speed	:	1-28, 36–60 ft/min
Nozzle Temperature	:	50 °C – 800 °C
Nozzle Unit	:	22.0 mm standard, other optional
Upper Roller Width	:	25.4 mm
Lower Roller Width	:	31.0 mm
Overall Dimensions	:	1200 mm (L) x 660 mm (W) x 1800 mm (H)
Overall Weight	:	130 kg

Note : due to continuous improvement, specifications are subjected to change without prior notification

> **Features**

- Real time variable speed sealing for non-stop long seam, ideal for narrow tape running on curve as well as improving waterproof on crossed seam.
- Differential speed for top and bottom rollers, ideal for reducing stretch fabric puckering.
- Electronic nozzle positioning adjustment by control panel entries, ensuring 100% repeatability.
- “Remember” function to store multi-nozzle position to be recall at a later time.
- Digital tape length counter, ideal for costing calculation.
- Multi-function foot pedal for easy one-footed control operation.
- Multi-lingual support for touch screen display interface.
- Heat press emulator function to simulate the function of heat press machine

> Identification of Components

>> Front View

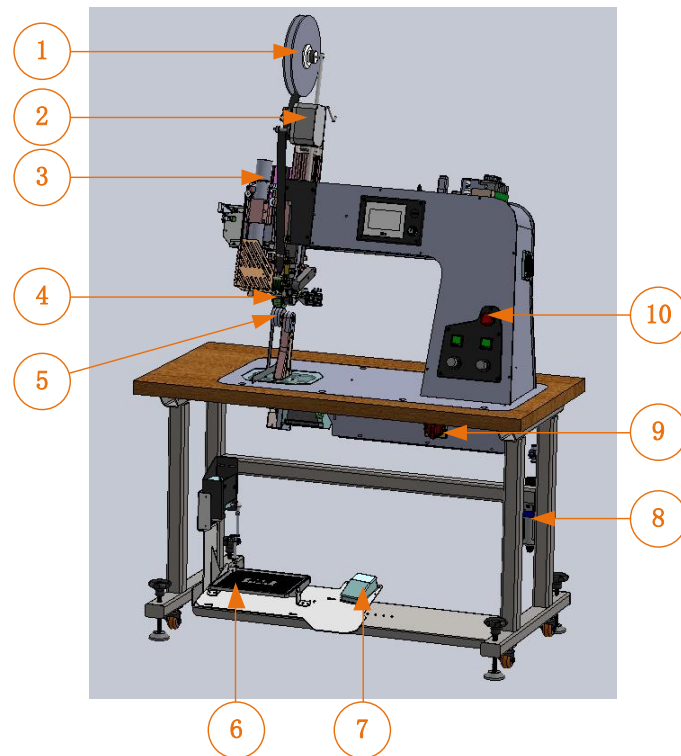

1. tape spool
2. tape dispenser
3. heater
4. upper roller
5. lower roller
6. left foot pedal
7. right foot pedal
8. water filter assembly
9. power switch
10. emergency stop switch

> Identification of Components (cont.)

>> Cutter Assembly

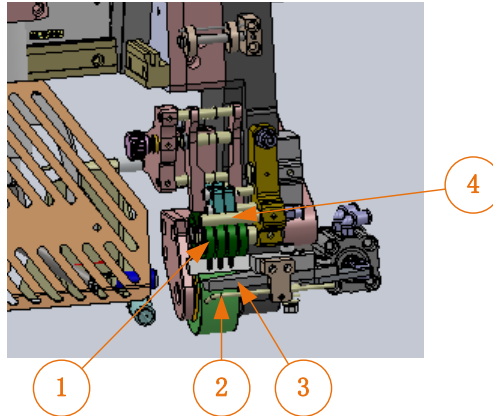

>> Heater Positioning Assembly (front)

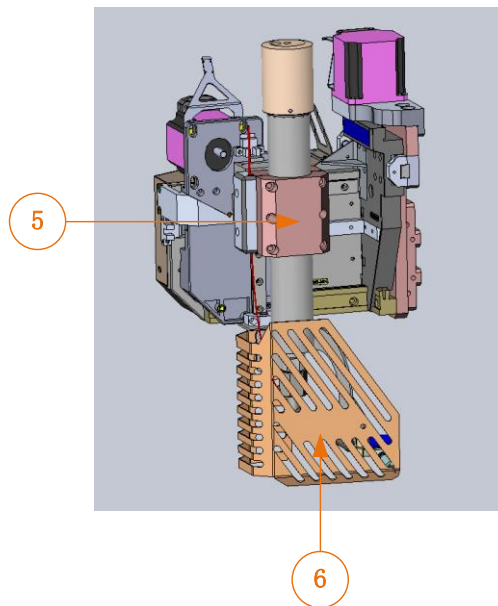

- 1. presser roller
- 2. blow forward
- 3. tape cutter
- 4. tape feed blowing
- 5. heater holder
- 6. heater shroud

> Identification of Components (cont.)

>> Heater Positioning Assembly (rear)

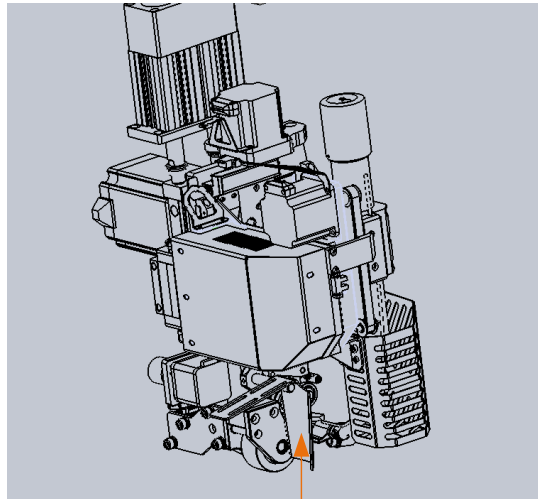

1

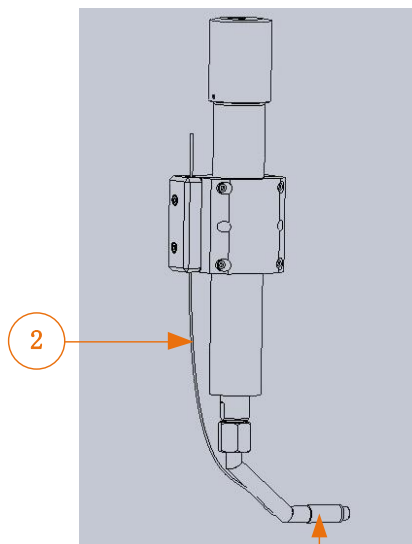

2

3

1. hot air deflector
2. temperature sensor
3. air nozzle

> Identification of Components (cont.)

>> Touch Screen Control Panel & Pressure Adjustment Panel

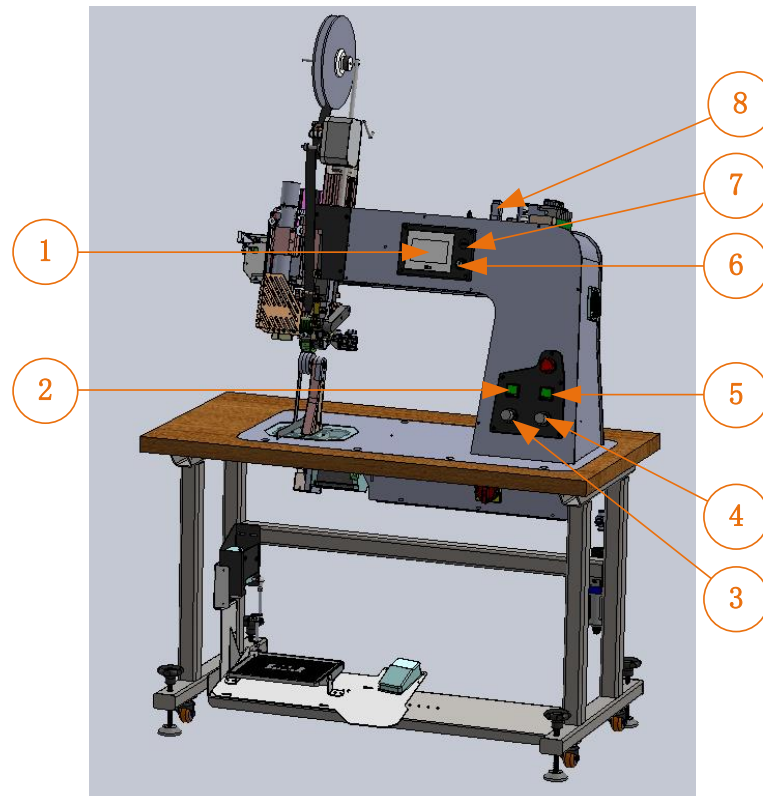

1. touch screen control panel
2. digital nozzle pressure display
3. nozzle air pressure regulator
4. nip roller pressure regulator
5. digital nip roller pressure display
6. data lock
7. USB socket
8. heater power outlet

> Principle of Seam Sealing

When seam tape is heated up, the adhesive on the tape is activated. This activated tape is applied on the water proof coating or lamination of the fabric seam under pressure. When cooled, a strong bond is formed between the tape and the seam. This bond is so strong that it will prevent pressurized water from penetrating the sewn seam. As a result, a water proof seam is produced.

A hot air machine, like AI-002, produces hot air with precisely controlled temperature to directly heat up the adhesive of seam tape. The heated tape and the fabric are feeding into two oppositely rotating rollers under pressure called nip rollers. The linear speed of the nip rollers is called sealing speed.

During sealing, hot air is being blown out from the nozzle. The hot air that actually reaches the surface of the tape is a mixture of hot air from the nozzle and surrounding air, hence the actual temperature that appeared on the tape is somewhat lower than the nozzle temperature. The farther the distance between the nozzle and the tape, the higher the percentage of surrounding air becomes. On the other hand, a higher hot air flow rate will reduce the percentage of surrounding air causing the hot air temperature appeared on the tape to be higher. So both the nozzle position and hot air flow rate are very important factors.

So, the major factors that can affect the seam sealing are as follows:

Hot air temperature

Sealing speed

Nozzle air pressure

Air flow rate

Nozzle position

When a consistent product is required, the combination of the above factors have to be set precisely as their effects towards a proper sealing are all interconnecting.

> Preparation for Installation

Installation must be carried out by authorized personnel. Follow the steps below:

1. Position the machine on a flat surface and allow at least 50cm clearance on both sides as well as the back side, this is essential for the hot air deflector to work properly and also to allow enough room for carrying out necessary service and maintenance
2. Adjust the foot stand so that the machine is level and stable.
3. Cut loose all packing cable ties and materials in order to free up all machine movements.
4. Connect the power plug to a suitable outlet with at least 15A capacity.
5. Locate the air hose supplied with the machine. Connect one end to the inlet of the water filter at the back side of the machine; connect the other end to a compressed air supply such as air compressor or central air supply. Make sure the compressed air supply has at least 0.6 Mpa (6 bar) of pressure and a flow rate of no less than 100L/min.
6. Install the tape dispenser assembly at the top of the machine and align the tape spool at right angle to the width of the machine. (see diagram below)

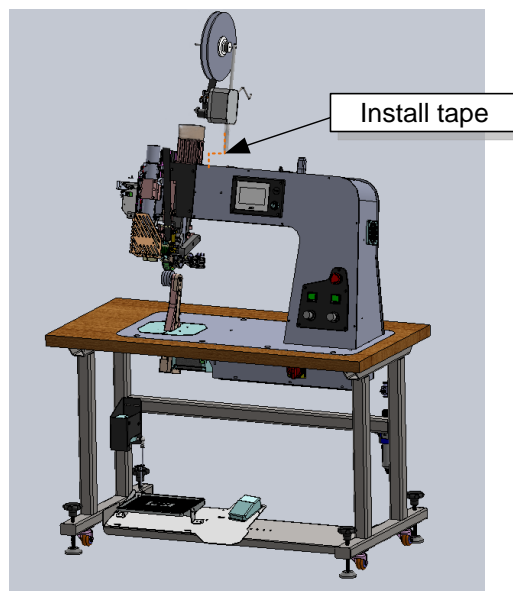

7. Install a roll of seam tape with the adhesive side facing the operator (refer to the section on tape loading).
8. The machine is now ready for operation.

> Control Method

>> Touch Screen Control Panel

Almost all settings and timing control of the machines can be input from the touch screen control panel. Use your finger tip to touch the parameter to be modified. Switch to different pages to modify other parameters (refer to section on control menu navigation). The screen has a protective cover to prevent the surface from damage and scratch, however, avoid using excessive force when touching the panel. You can also change the contrast of the display so as to obtain the best picture when viewing at a different angle.

>> Foot Switch

There are 2 foot pedals for the machine. The design of these pedals is such that they can be operated either individually or in combination to achieve a number of preset tasks by the operator's feet only. As a result, the operator's hands are free to manipulate the processing fabric.

Left foot pedal

The left pedal is a multi function pedal. You can use it to raise the upper roller and start sealing .

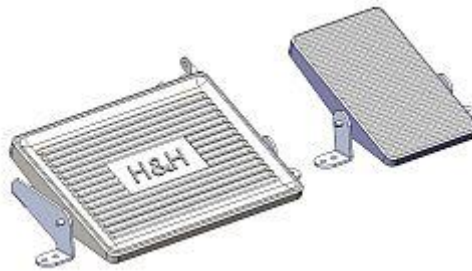

To raise the upper roller - heel back the left foot pedal.

To start sealing - press forward.

Right foot pedal

The right pedal is a simple switch. It performs different function according to the timing.

During idle – jog function that makes the rollers rotate forward without the nozzle coming in.

During idle – cut function that cuts the tape if left pedal is in heel back position.

During sealing – cut function that cuts the tape

> **Control Method (cont.)**

>> **Control Menu Navigation**

The AI-002 has many parameters that can be adjusted according to the operational situations. These parameters are arranged in different menu pages on the touch screen control panel according to their functionality. The structure of the menu page arrangement is represented in the following diagram.

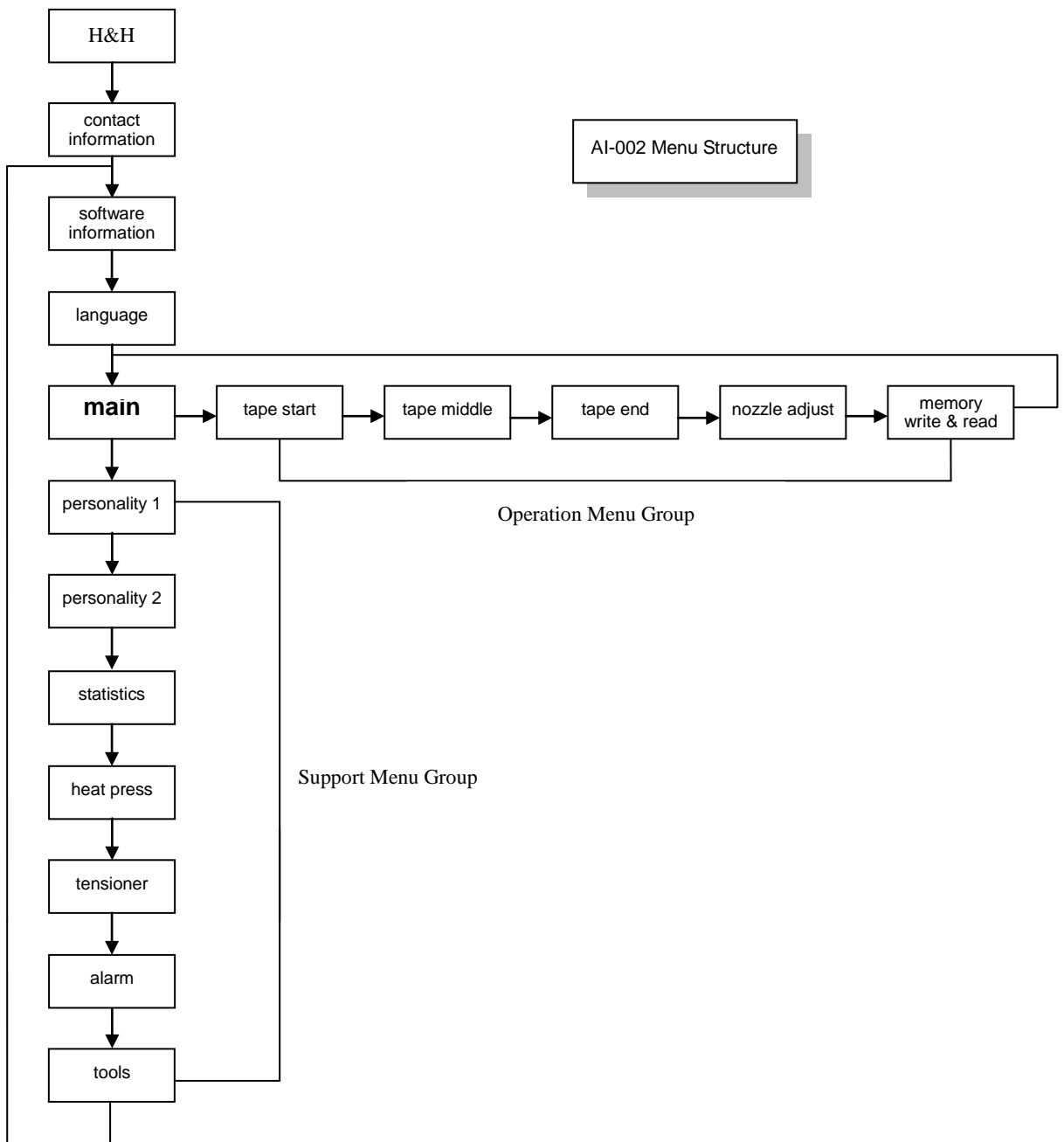

> Control Method (cont.)

>> Control Menu Navigation (cont.)

The followings are typical menu pages, all of them have names at the top left corner for easy identification. Right arrow buttons are for navigating in the operation menu group. Down arrow buttons are for navigating in the support menu group. Please note that page 'main' is the hub of the menu network so only this page has navigation buttons for both operation and support menu groups.

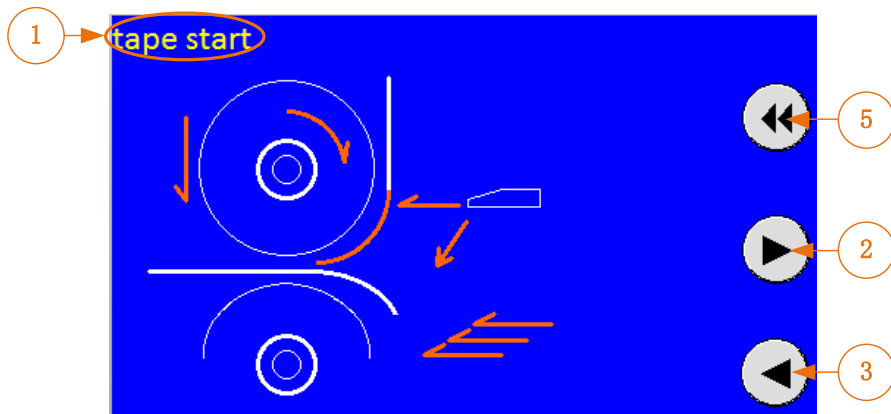
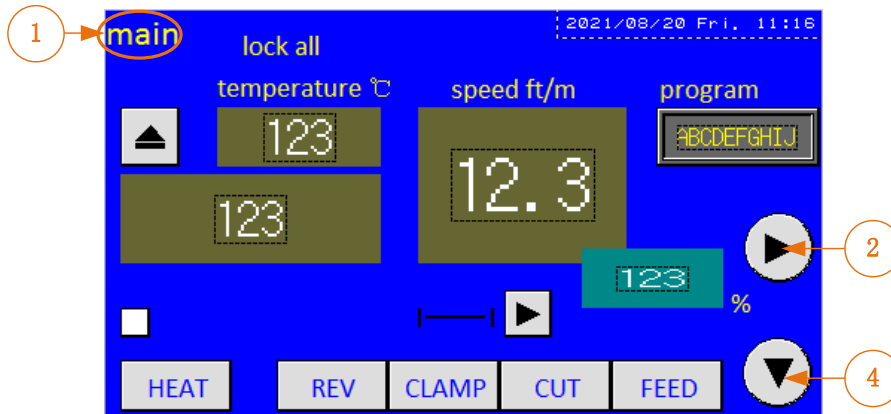

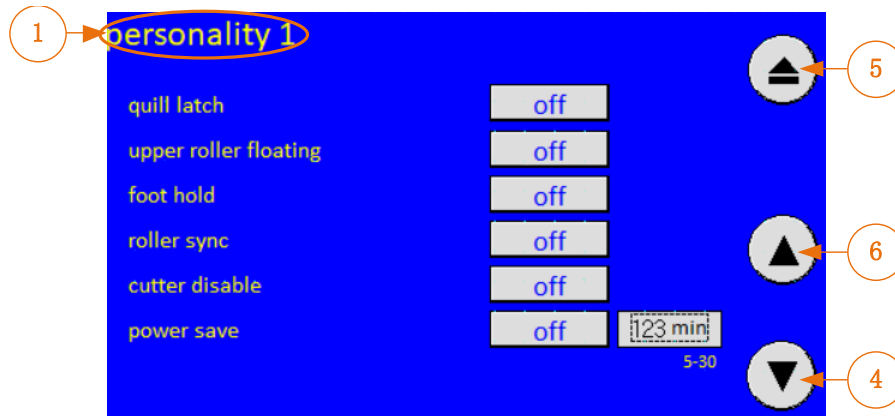

1. page name
2. next page in the operation menu group
3. previous page in the operation menu group
4. next page in the support menu group
5. hot key to return to page "main"
6. previous page in the support menu group

> Control Method (cont.)

>> Pressure Adjustment

To adjust corresponding pressure, pull out the adjusting knob by one notch, turn the knob clockwise or anti-clockwise to increase or decrease the needed pressure accordingly. When finished, lock the air regulator pressure by pushing the adjusting knob toward the regulator.

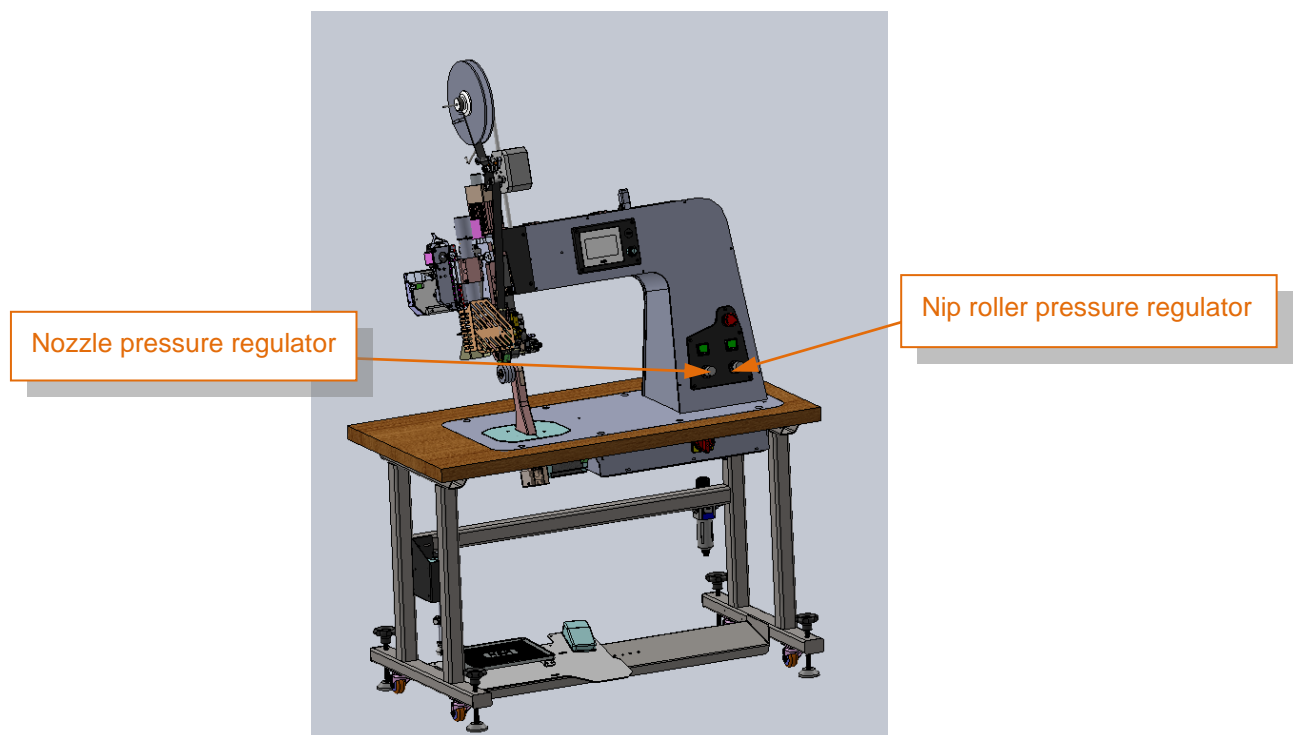

> Start Up and Shut Down Procedures

>> Start up Procedures

1. Switch on the compressed air by turning the main air ON/OFF switch knob
2. Turn on the machine by pressing the green power ON button
3. Enable the heating by pressing the HEAT button once the 'main' page is displayed

Initially the display will page thru some important information about this machine.



This page shows the contact information of the manufacturer.

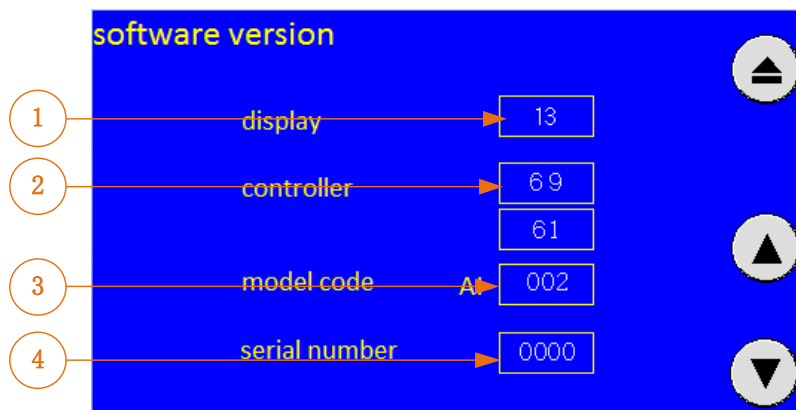

This page shows the important configuration of this machine by the manufacturer. Please record down this information from the display for future reference and/or upgrade.

1. software version for display panel
2. software version for main controller
3. model code for this machine
4. serial number for this machine

> Start Up and Shut Down Procedures (cont.)

>> Start up Procedures (cont.)

While the language page is displayed, you can choose the preferred language for this machine.

The display will store this selection even after the power is switched off.



1. Press to change to English display.
2. Press to change to Simplified Chinese display.
3. Press to change to Traditional Chinese display.
4. Press to change to Vietnamese display.
5. Press to change to Indo display.

After about 10 seconds, the page “main” is displayed meaning the machine is ready for operation.

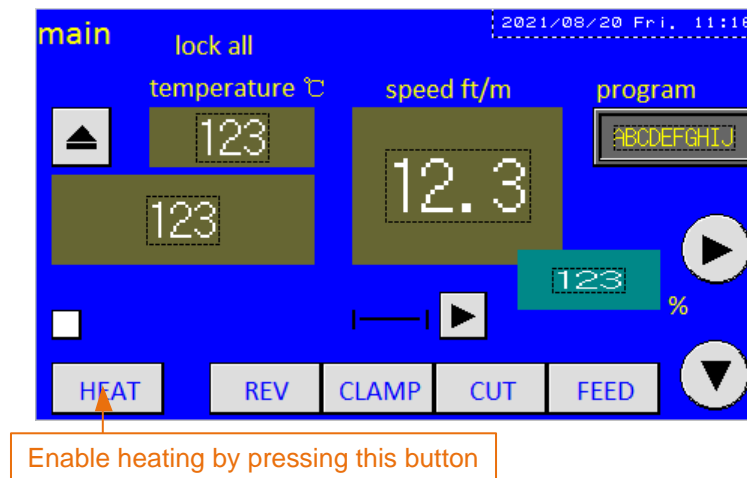

IMPORTANT NOTICE !

Briefly after the power is switched on, the electronic nozzle positioning system will relocate the nozzle to a predefined position called home position. During the homing process, do not interfere with the motion of the heater as the machine may pick up incorrect data resulting in incorrect nozzle position in the subsequence operation.

> Start Up and Shut Down Procedures (cont.)

>> Shut down Procedures

1. Disable the heating by pressing the HEAT button if the machine is previously in the heating mode.
2. Observe the indicated nozzle temperature, the temperature should gradually drop.
3. Wait until the nozzle temperature cool down to 60 °C and below, depending on the previous temperature and surrounding environment, it may take 5-10 minutes.
4. Confirm that the temperature is below 60 °C, switch off the machine by pressing the red power OFF button.
5. Follow by switching off the compressed air by turning the main air ON/OFF switch knob.

WARNING !

Shut down procedures must be followed strictly to avoid damage to the heater. Always cool down the heater before shutting off the compressed air supply.

> Basic Operation

Please note the locations of basic parameters that you need to set before operating the machine.

Refer to the corresponding sections for detail explanation.

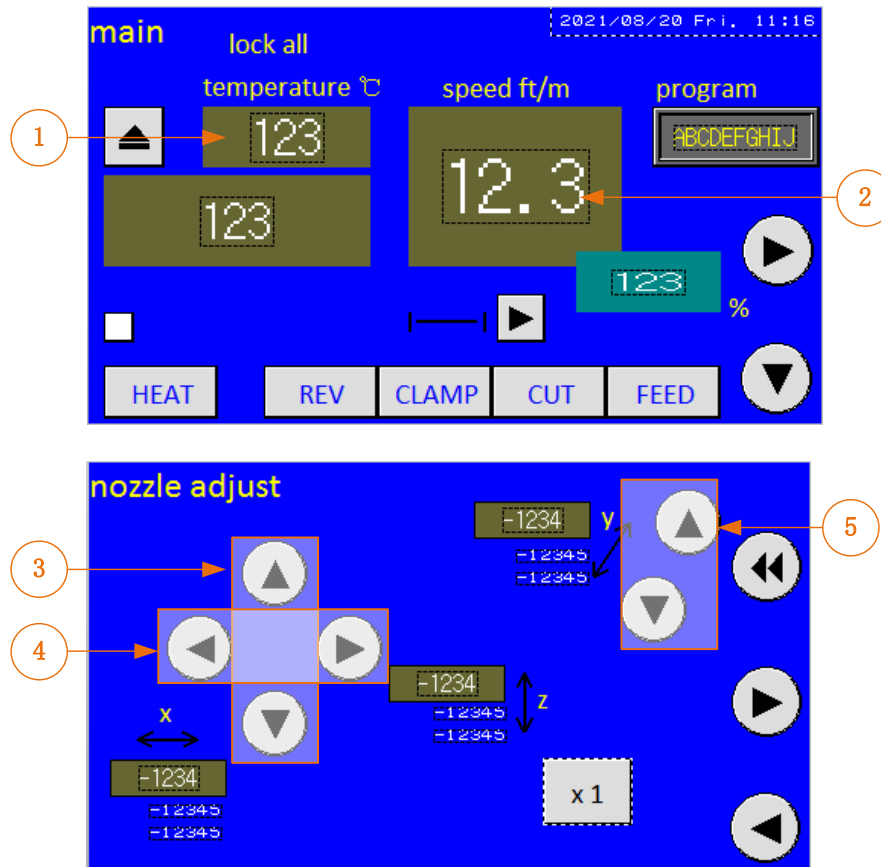

1. temperature
2. sealing speed
3. nozzle position (up-down adjustment)
4. nozzle position (left-right adjustment)
5. nozzle position (in-out adjustment)

> **Basic Operation** (cont.)

>> **Procedures of Seam Sealing**

Set the heater temperature, nozzle air pressure and fabric speed to the desired values. To begin with, set to 400°C, 0.1Mpa and 12ft/min accordingly. This should be a fair setting to start with. However, other setting can be used depending on the actual situation.

Activate the RUN (left foot) pedal momentarily, check the position of the nozzle and adjust accordingly.

Insert the seam tape through the tape stabilizer and the white tape presser roller, activate the JOG (right foot) pedal to advance the tape towards the nip rollers. The tape must be position in the middle and with the adhesive side facing towards the operator. Adjust the sealing tape to proper tension and running position (refer to section on tape loading)

Raise the upper nip roller by heeling back the left foot pedal, put the tape and the sewn seam in the center and release the left foot pedal so that the upper nip roller presses on the tape and seam tightly.

Collect the seam with both hands until the starting point can be reached by fingers. Position the forearms on the table and smooth out the seam with your fingers.

Activate the RUN (left foot) pedal, the hot air nozzle will engage and the nip rollers will start turning and draw the tape and the seam in between the nip rollers. Release the seam while keeping it in the center of the lower nip roller.

Near the end of tape, step on the right foot pedal while left foot pedal is still down. This will cut the tape, the upper nip roller will rise and new section of tape is fed.

The first seam sealing is completed; resume sealing for the next seam.

>> **Tape Cutting**

During sealing - while the left foot pedal is in forward sealing position, press on the right foot to cut the tape.

Idling – manually press the **CUT** button on the touch screen to cut the tape

Idling – while the left foot pedal is in the heel back position, press on the right foot to cut the tape.

> Basic Operation (cont.)

>> Tape Loading

Load the tape on the spool and route the tape thru the tape dispenser as shown below. Make sure the adhesive side of the tape is facing the operator when installing the tape.

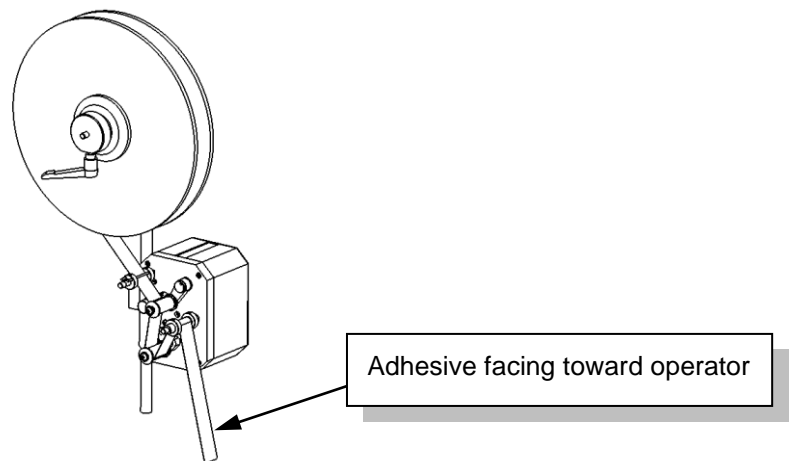

> Basic Operation (cont.)

>> Nozzle

When inserting the tape thru the cutter area, it is best to place the nozzle in the park position. At this time, the tape clamp will be released to facilitate the tape insertion.

Go to page 'main' and press the nozzle parking button.

Press to park or un-park the nozzle

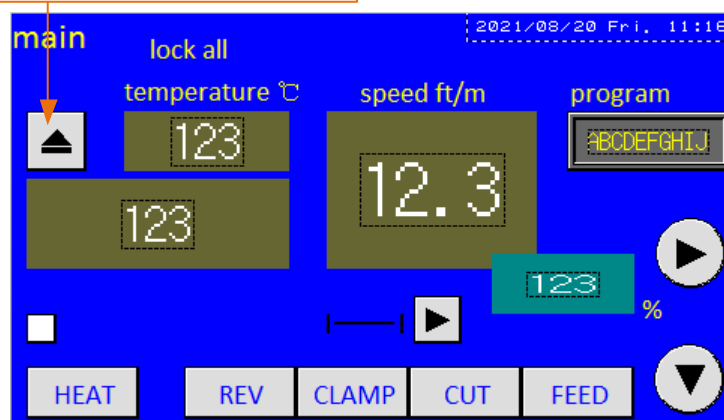

When parked, the nozzle is moved to a position farther away from the operator. This gives a cleaner look at the cutter opening for a more convenient tape loading. This is also safer as the chance of getting burn by the nozzle is minimal.

> **Advance Operation**

In the past, hot air machines had been built with similar technology. Factory users were forced to compromise between quality and efficiency as fundamental problems in seam sealing still exist in day to day production.

The AI-002 hot air sealing machine is engineered to make seam sealing much easier than before. Unique features allow you to fine tune sealing conditions in the time domain level, eliminating traditional problems.

These features including but not limiting to the follows:

Quill latch

Upper roller floating

Foot hold

Roller sync

Cutter disable

Power save

Advance mode

Differential speed

Electronic nozzle position adjustment

Memory

Individual program for start/ middle/ end of tape

Digital tensioner

Alarm

> Advance operation (cont.)

>> Personality 1

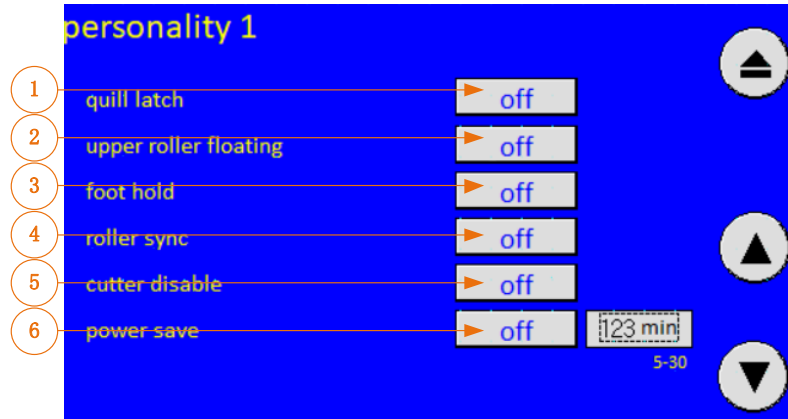

1. Press to turn on/off the quill latch. This feature allows the upper roller to latch in the up position after tape is cut. If this function is off, the upper roller will come down after the tape is fed.
2. Press to turn on/off the upper roller floating. If this function is off, after cut sequence the upper roller will not float.
3. Press to turn on/off the foot hold. This feature is used to control the after cut sequence. During this mode, the after cut sequence will be finished even the left foot pedal is released after the cutting. If this function is off, the after cut sequence is cancelled when left foot pedal is released.
4. Press to turn on/off roller sync. This feature on/off the lower roller to rotate (sync) during a tape feed operation after tape is cut. When off, lower roller does not rotate can avoid dragging the garment during a after cut tape feeding, especially when the lower roller is rubber.
5. Press to turn on/off the cutter disable. If this function is on, the cutter will not work.
6. Press to turn on/off the power saving mode. This feature is used to conserve electricity when the machine is idle. If this function is on, the nozzle will be turned off if machine is idle (both foot switches not operating) for 10 minutes. Operating either of the pedals will reset this timer. A reminder counter will appear next to the heat button during the last 5 minutes before shutting down.

> Advance Operation (cont.)

>> Advance Mode

Traditional hot air machine has only two nozzle positions, swing in and swing out. AI-002 has an additional position called 'hovering' position in between.

The new feature 'advance mode' keeps the nozzle in the 'hovering' position during temporary stop.

When the advance mode is enabled, the hovering nozzle will keep the seam tape warm to improve water leakage problem during start/stop operation.

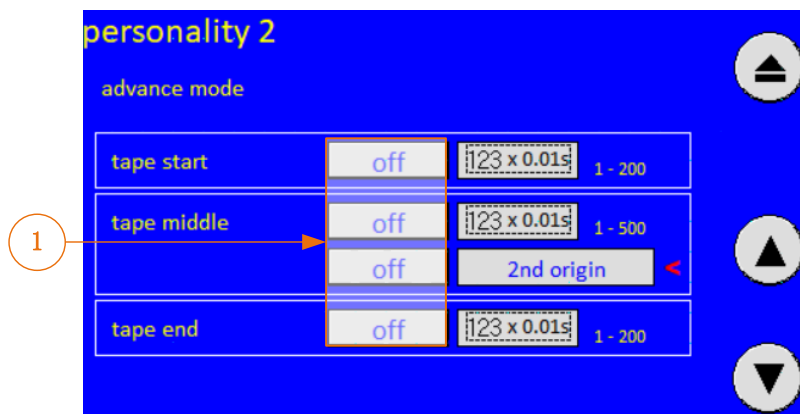

1. Press to turn on/off the advance mode.

During advance mode, the nozzle will only stay in the hovering position for a maximum of 5 seconds. After that the nozzle will move back to the home position.

> Advance Operation (cont.)

>> Differential Speed

This feature allows the operator to set the upper and lower rollers to run at a slightly different speed.

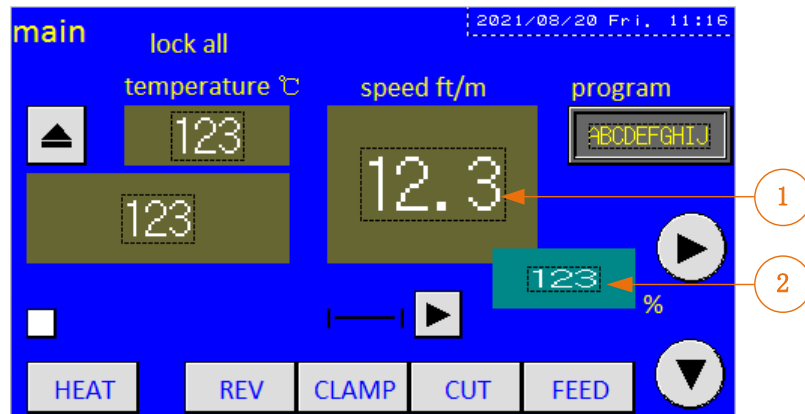

1. Preset the sealing speed.
2. Press to set the sealing speed to change in %.

While the upper roller is running at the preset sealing speed, the lower roller is running at a speed according to the % (percentage) setting.

Lower roller speed = preset sealing speed x % setting

If differential speed setting = 100%, lower roller is running at the same speed as the upper roller.
 If differential speed setting > 100%, lower roller is running at a faster speed than the upper roller.
 If differential speed setting < 100%, lower roller is running at a slower speed than the upper roller.

The range of percentage setting is 80–150 %.

WARNING !

When using larger differential speed < 90% or > 110%. Always place a piece of fabric between the nip rollers. Failure to do so may cause excessive stress in the transmission system which may in turn damage the machine parts

TIPS :

To compensate puckering due to stretchiness of fabric

To compensate puckering due to uneven worn out of upper and bottom rollers

To improve a phenomenon called 'bamboo shell' on some kind of fabric

> Advance Operation (cont.)

>> Electronic Nozzle Position Adjustment

This feature allows the operator to adjust nozzle position electronically by input on the touch screen display panel.

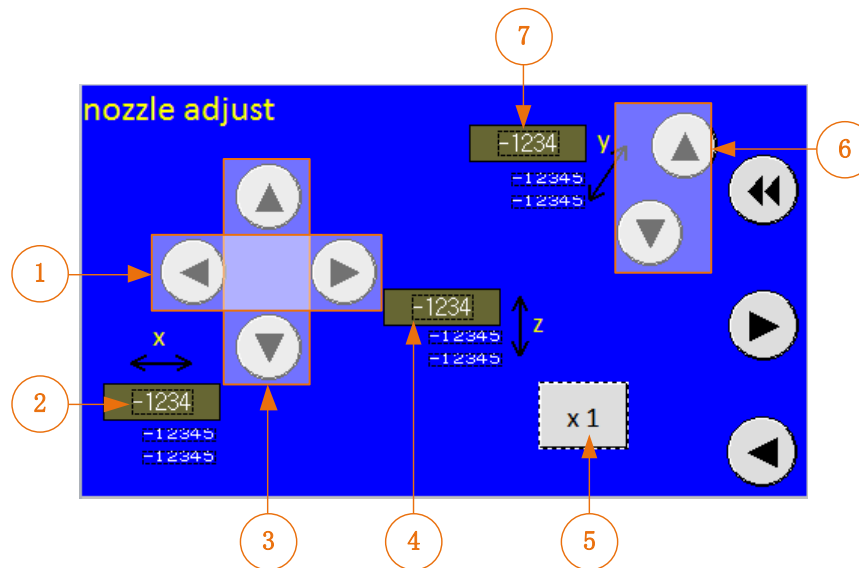

1. x direction adjustment buttons (left + right)
2. x direction nozzle position setting
3. z direction adjustment buttons (up + down)
4. z direction nozzle position setting
5. multiplier button for all x, y, z direction adjustment.
6. y direction adjustment buttons (in + out)
7. y direction nozzle position setting

> Advance Operation (cont.)

>> Electronic Nozzle Position Adjustment (cont.)

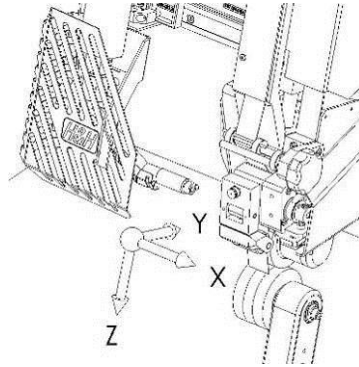

The normal nozzle adjustment is full speed mode, this is the nozzle position when the roller is running at preset sealing speed. Then start sealing using some test fabric and tape. Adjust the x-direction and the z-direction by pressing on the corresponding buttons while the nozzle is engaged. Adjust the distance between the nozzle and roller by the y-direction buttons so as to generate the best sealing result. You may need to have the test fabric go thru some predefined testing procedures (like hydrostatic test, wash test, etc.) before confirming the correct settings.

When finished nozzle adjustment, exit from the page 'nozzle adjust' to resume normal operation.

WARNING !

The nozzle position is allowed to be adjusted in any position in the 3-dimensional space, within the range. When adjusting nozzle very close to the roller, be careful to avoid the nozzle from hitting the roller. This can be done by adjusting a little bit at a time while keeping eyes on the gap. Failure to do so may cause damage to the nozzle positioning system.

> Advance Operation (cont.)

>> Memory

All operating parameters of the machine including operation data, nozzle position and personality can be stored into one of the 20 memory locations. The data from these locations can be recalled as the current machine setting at any time.

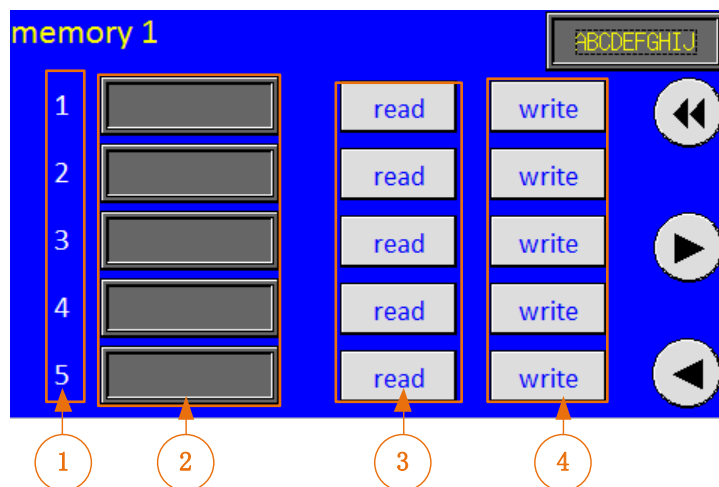

1. The number of memory.
2. The name of memory.
3. Press and hold the button that the data wanted to be retrieved for 5 seconds, a beep will sound to confirm that the data in that location is read and copied in the current machine setting area.
4. Press and hold the button of memory location wanted to store data for 5 seconds, a beep will sound to confirm the storage is successful.

WARNING !

Please note that the area to be written (either system area or memory locations) do not have any useful settings before transferring data. Once the data is copied, the original data in the target is overwritten.

> Advance Operation (cont.)

>> Individual Program for Start/ Middle/ End of Tape

AI-002 can recognize the stage of tape sealing, individual programs can be used to change the behavior of the machines according to whether the stage is in the start, middle or end of sealing. To invoke the set up pages of these programs, touch the respective area in the seam tape graphic symbols as illustrated below:

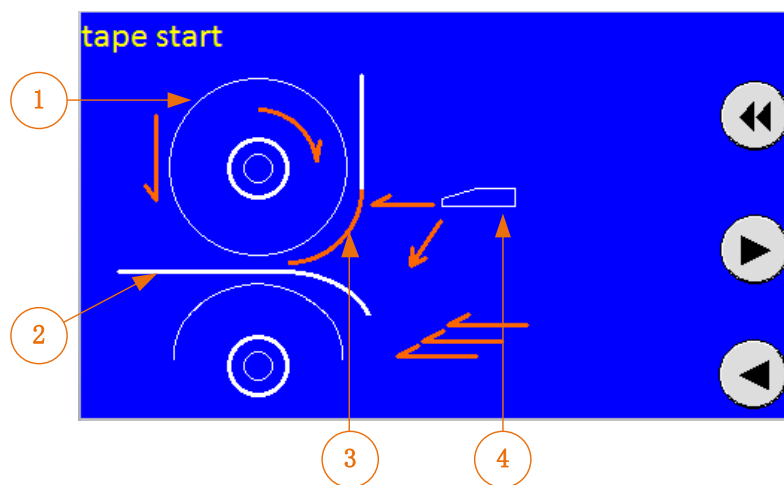

1. upper roller symbol
2. fabric symbol
3. seam tape symbol
4. air nozzle symbol

On the individual programming pages, parameters that can be altered are represented by blinking symbols. Touch these symbols to enter into corresponding data entry mode. Simple explanation and range of the parameter will be shown up at this time.

Note:

Since the operating software is being upgraded constantly to accommodate new features, please refer to the on screen menu and Appendix D for further explanation.

> **Advance Operation (cont.)**

>> **Digital Tensioner**

During seam sealing, the consistent supply of seam tape to the sealing area is important . Your AI-002 is equipped with a built in digital tensioner to release the seam tape from the tape spool. Route the tape exactly as shown in the below diagram.

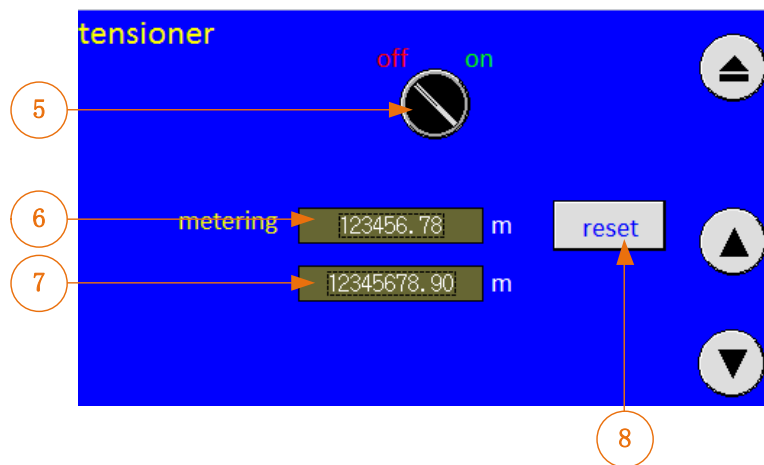
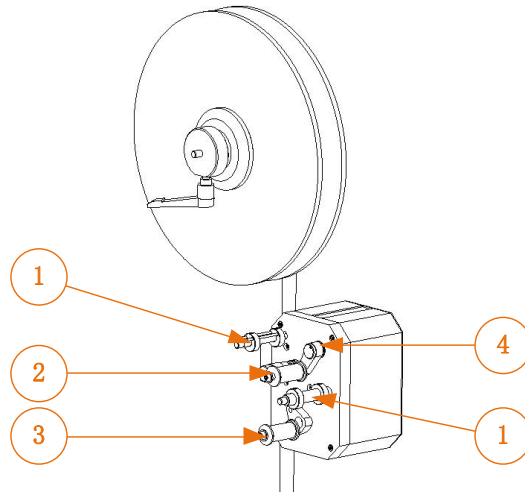

1. tape stabilizer
2. drive roller
3. swing sensor
4. tensioner press roller
5. tension on/off switch
6. tape length counter (can be reset)
7. tape length counter (cannot be reset)
8. tape length counter reset button

> Advance Operation (cont.)

>> Alarm

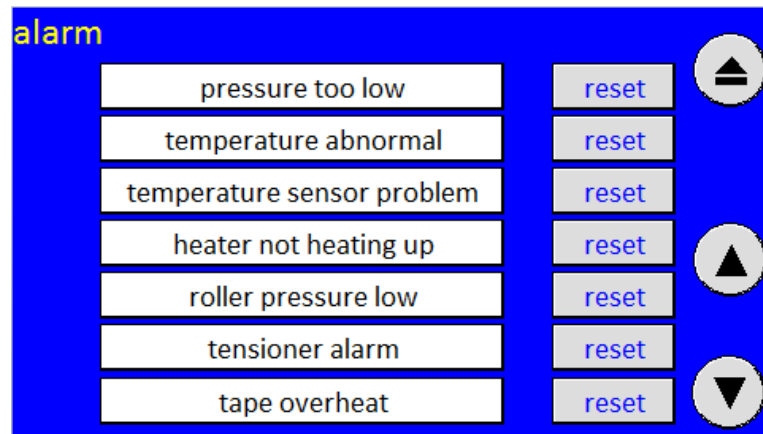

You can reset the alarm when the selected alarm is disabled or the fault is fixed.

> Maintenance

>> Preventative

In order to keep the machine in top running condition, regular maintenance is important for trouble free operation. This will minimize possible down time and to prolong machine life.

Daily

- Check the motion of the machine for smoothness and strange noise.
- Check the air hoses for leakage or damage.
- Check silicone roller for worn or damaged.

Weekly

- Check all rollers for excessive play, all play should be less than 5 mm, adjust the corresponding cam belt tension if necessary.
- Lubricate the cutter blade slightly with machine oil. Wipe off any excessive oil if necessary.
- While the machine is off and cooled, test the circuit breaker by pressing the test button. The handle should flip to OFF immediately.
- Check the speed of the nip roller cylinder. Adjust the speed by the air speed regulators located under the touch screen control panel if necessary.
- Visually inspect all the electrical and mechanical parts for abnormal burns and looseness.
- Check the nozzle air pressure interlock: lower the nozzle air pressure gradually to below 0.05 Mpa, an alarm message should appear and the heater power will be cut off followed by a drop in heater temperature.
- Next increase the air pressure to above 0.1 Mpa, the alarm message 'pressure low' in the page 'main' should disappear.

As Required

- Clean the rollers to remove any adhesive residue, which may cause fabric wrapping.
- Replace the silicone roller by a new one if necessary.
- Replace heater element if damaged, be careful not to allow material being broken off from the old element causing blockage to the air passages.
- If nozzle is blocked, remove the nozzle from the heater and tap it gently to release foreign material from the inlet side.

> Maintenance (cont.)

>> Procedures for Replacing Parts

Temperature sensor

The tip of the replaced thermocouple is very important, the location must be the same as shown in the below diagram. Also inspect and make sure that the tip is in the center of the pipe and not touching the metal part. This is essential for the sensor to measure the air temperature correctly.

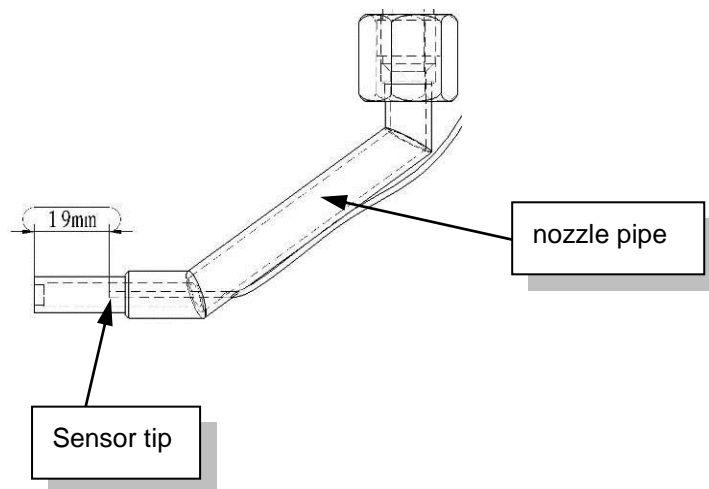

Heater Element

Remove the heater top cap and the heater securing mount to locate the heater element. Carefully pull the element off the connecting sockets. Replace the broken element with a new one. Installation is just the reversal. After replacing a new heater element, run the machine at 300 °C for at least 10 minutes to break in the heater before operating at higher temperature.

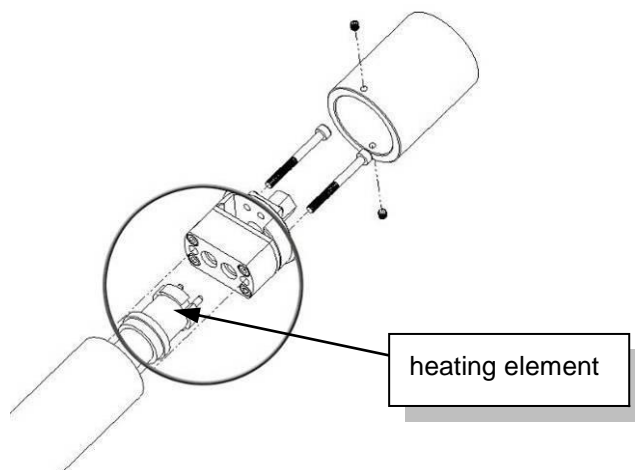

> Maintenance (cont.)

>> Procedures for Replacing Parts (cont.)

Rollers

The rollers are needed to be replaced when there are signs of torn or excessive worn in order to maintain the consistence of quality of the finished product. Replace the rollers as shown in the illustration below. Please choose the correct width and softness roller. For best result, always use genuine H&H parts for replacement. Please contact us for optional sizes.

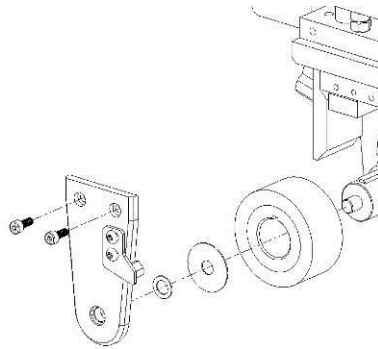

upper roller

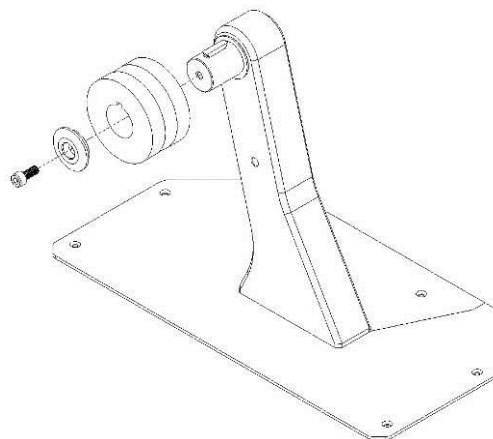

lower roller

> Trouble Shooting

Problem	cause	solution
No power in some places	Power cable or plug faulty	Check the power supply connection
	Circuit breaker tripped	Reset circuit breaker and investigate the cause
	Main power switch not turned on	Press the power ON button (start)
	Bad connection	Check all wires for loose connection
	Faulty transformer	Check the voltage of switching power supply
Motor not turning	Nozzle in park position	Un-park the nozzle
	Faulty Main controller	Replace a new controller
Temperature display not stable	Faulty thermocouple	Replace a new temperature sensor
	Loose thermocouple connection	Check and secure the connection
	Faulty temperature controller	Replace PCB in the main electrical box
	Thermocouple extension wire short circuit	Find the location and fix
	Thermocouple not installed in proper position	Check the position of sensor tip and fix
Temperature display read ambient at all time	Heater is not turned on	Press HEAT to enable heater
	Air pressure too low	Inspect if air supply is cut off
Temperature fluctuate abnormally	Broken heater element	Replace heater element
	Faulty thermocouple	Replace thermocouple
	Hose tangled	Check for hose clearance or pinch during heater movement
	Line voltage fluctuation	Install voltage regulator
	Loose object in air passage	Remove nozzle and clean the foreign material
Heater Not heating	Faulty solid state relay (SSR)	Replace solid state relay
	Pressure low interlocked	Increase nozzle air pressure
	Heater broken	Replace heater element

Appendix A . Nozzle Air Flow Cross Reference Table

Nozzle air pressure (Mpa)	Air flow (L/min)
0.05	35
0.06	38
0.07	40
0.08	42
0.09	45
0.10	48

Appendix B . Pneumatic Scheme

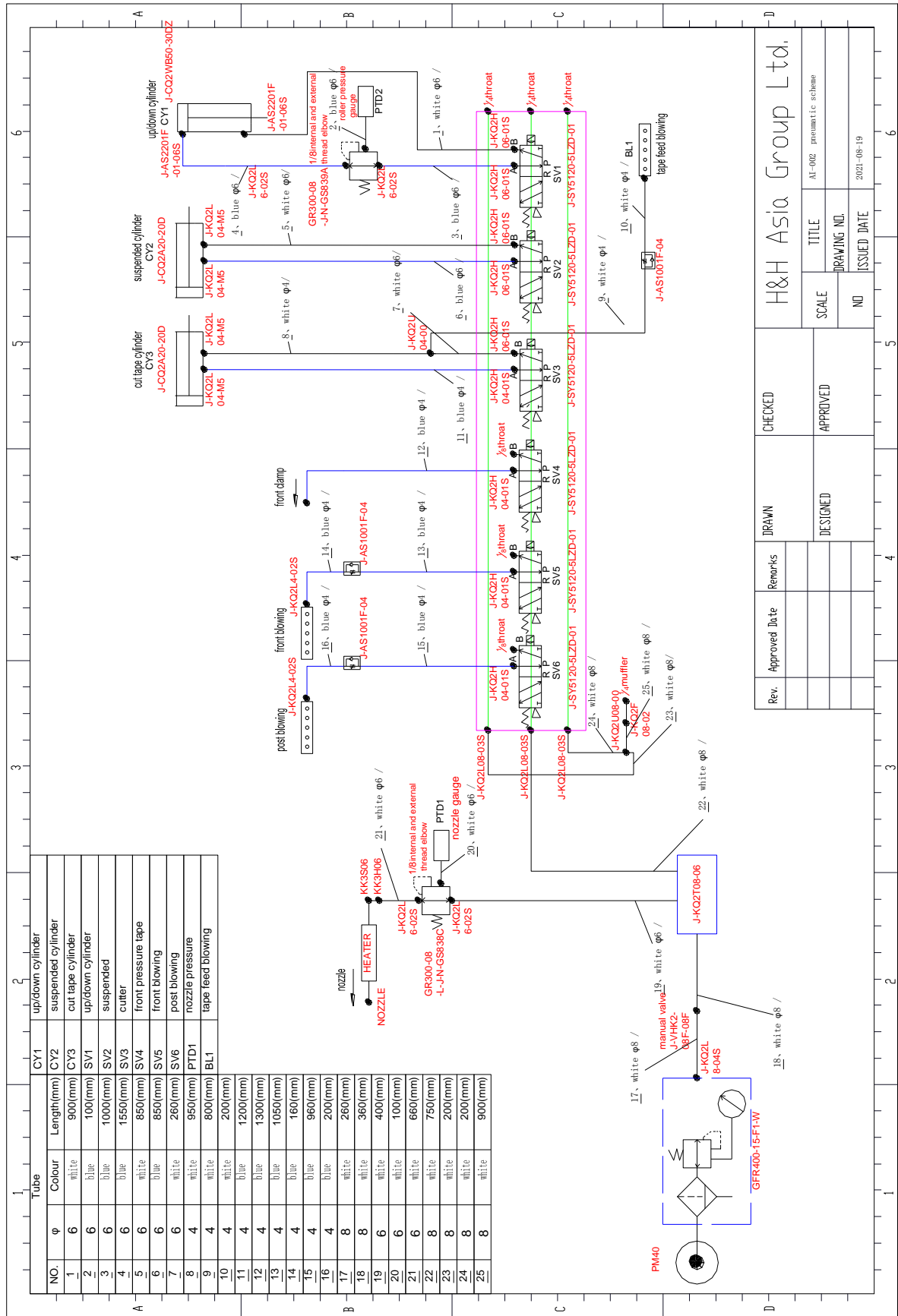

NO.	ψ	Colour	Length(mm)	up/down cylinder
1	6	white	900(mm)	CY2
2	6	blue	100(mm)	CY3
3	6	blue	1000(mm)	SV1
4	6	blue	1550(mm)	SV2
5	6	white	850(mm)	SV3
6	6	blue	850(mm)	SV4
7	6	white	260(mm)	SV5
8	4	white	950(mm)	SV6
9	4	white	800(mm)	PTD1
10	4	white	200(mm)	BL1
11	4	blue	1200(mm)	
12	4	blue	1300(mm)	
13	4	blue	1050(mm)	
14	4	blue	160(mm)	
15	4	blue	960(mm)	
16	4	blue	200(mm)	
17	8	white	260(mm)	
18	8	white	360(mm)	
19	6	white	400(mm)	
20	6	white	100(mm)	
21	6	white	660(mm)	
22	8	white	750(mm)	
23	8	white	200(mm)	
24	8	white	200(mm)	
25	8	white	900(mm)	

Rev.	Approved Date	Remarks	DRAWN	CHECKED	H&H Asia Group Ltd.	
			DESIGNED	APPROVED	SCALE	TITLE
					NO	AI-002 pneumatic scheme
						DRAWING NO.
						ISSUED DATE
						2021-08-19

Appendix C . Wiring Scheme

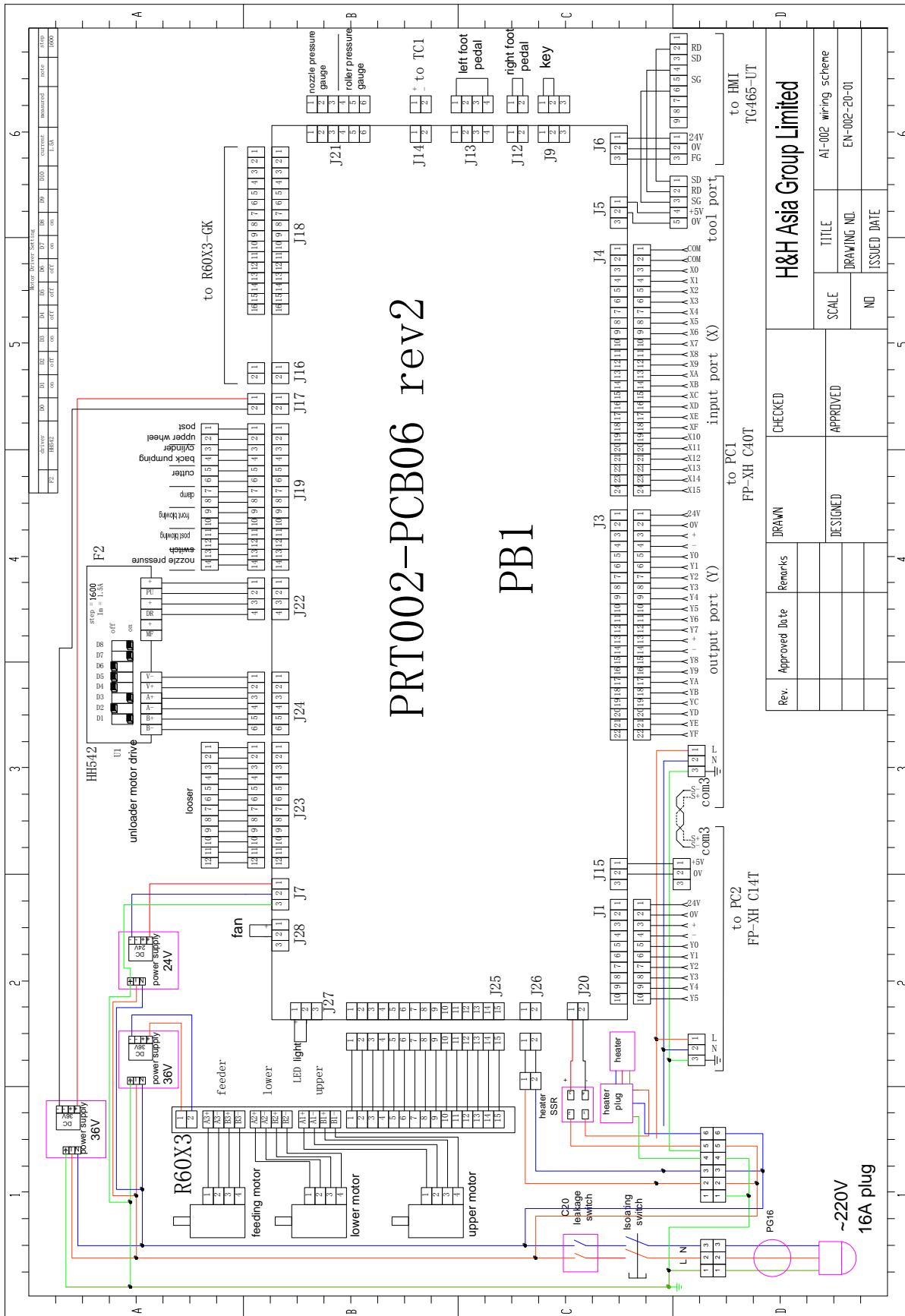

H&H Asia Group Limited	
TITLE	AI-002 wiring scheme
DRAWING NO.	EN-002-20-01
SCALE	NO
ISSUED DATE	
Rev.	Approved date
Remarks	
DESIGNED	APPROVED
DRAWN	CHECKED

Appendix D . Tape Start, Tape Middle, Tape End Parameters

> Tape Start Program

> Tape Start Program > start of tape quill delay

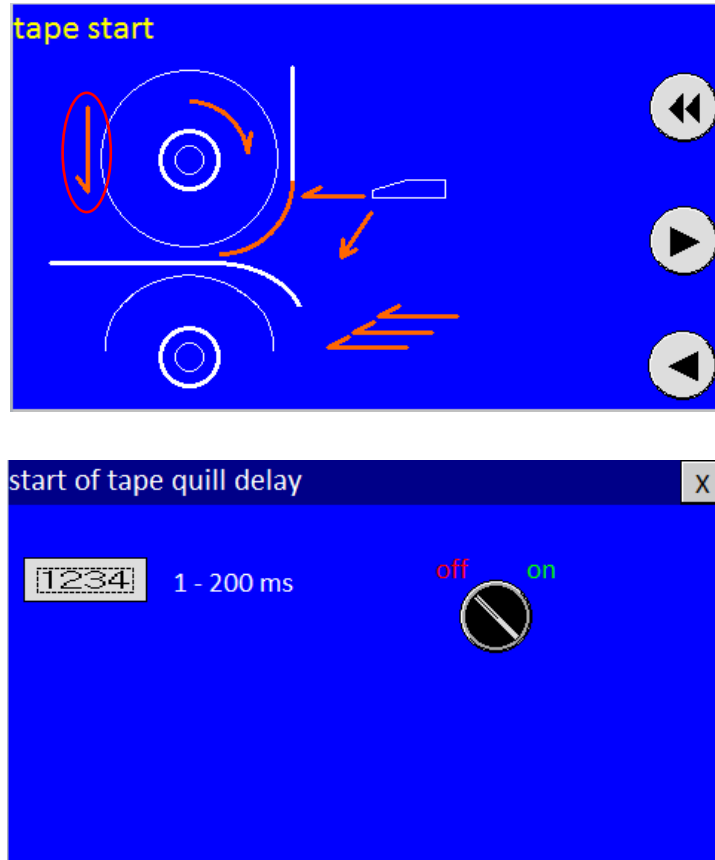

When the upper roller is in the UP position, pressing the left pedal forward will start the sealing process. The top roller will start to rotate and come down after a delay. Adjust this parameter to change this delay setting. Touch the ON/OFF button to enable/disable this function. If this delay is disabled, there will be no delay and the upper roller will come down immediately when foot pedal is presses.

Appendix D . Tape Start, Tape Middle, Tape End Parameters

> Tape Start Program (cont.)

> Tape Start Program > start of tape advance roller position

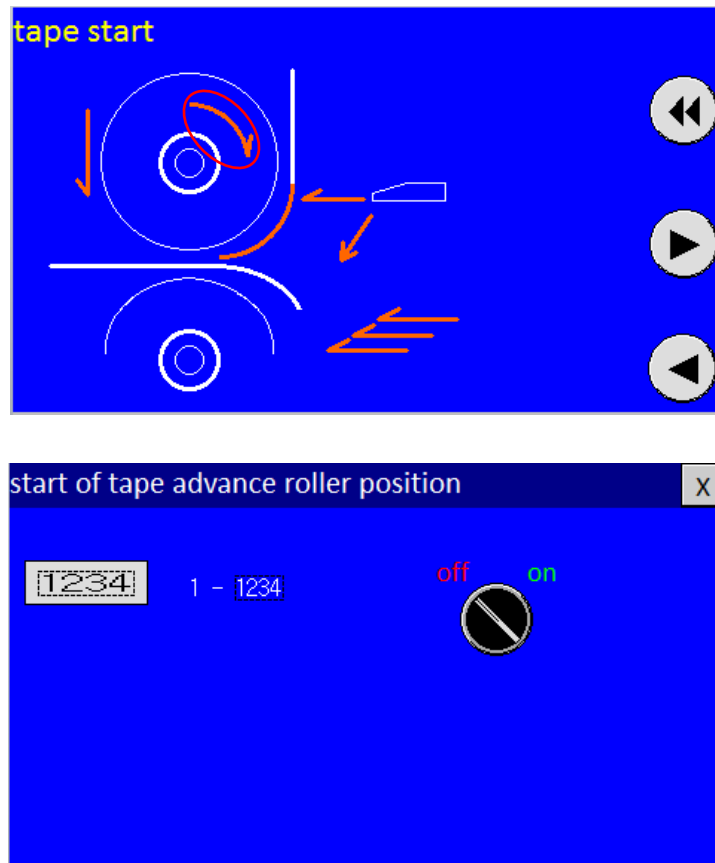

This setting controls the timing that the upper roller starts to rotate according to the position of the nozzle when the nozzle is going towards the upper roller. A small setting makes the upper roller rotate earlier while a larger setting makes the upper roller rotate later. This is used to control the heat absorption of the tape start. Touch the ON/OFF button to enable/disable this function. If this function is disabled, the upper roller rotate only after the nozzle arrived at the closest position to the upper roller.

Appendix D . Tape Start, Tape Middle, Tape End Parameters

> Tape Start Program (cont.)

> Tape Start Program > after cut tape feed length

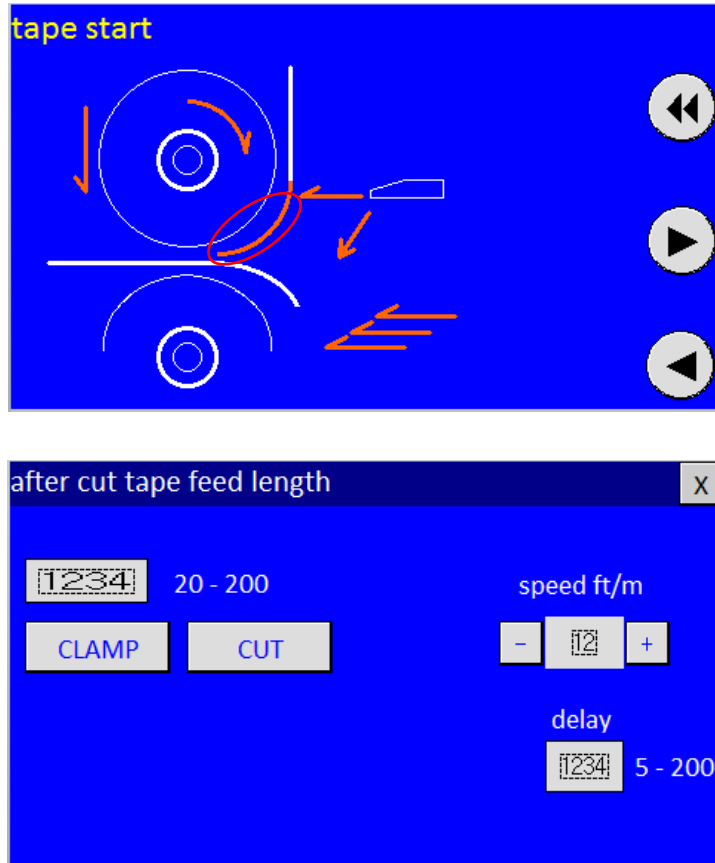

This setting controls the length of tape being fed after the tape is cut. Applies to both foot and hand initiated cutting.

Appendix D . Tape Start, Tape Middle, Tape End Parameters

> Tape Start Program (cont.)

> Tape Start Program > start of tape nozzle penetration speed

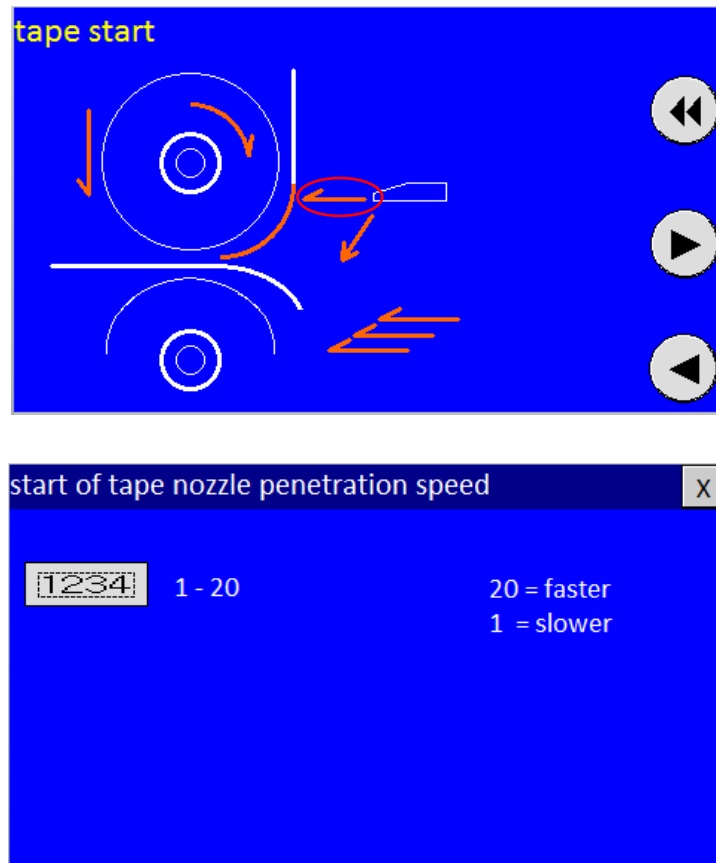

This setting controls the speed of nozzle moving towards the upper roller during a tape start. A tape start operation only happens once within the same tape. A smaller setting will increase the time it takes for the nozzle to move towards the upper roller during a start, but this will provide a more evenly heated tape start.

Appendix D . Tape Start, Tape Middle, Tape End Parameters

> Tape Start Program (cont.)

> Tape Start Program > tape start nozzle down offset

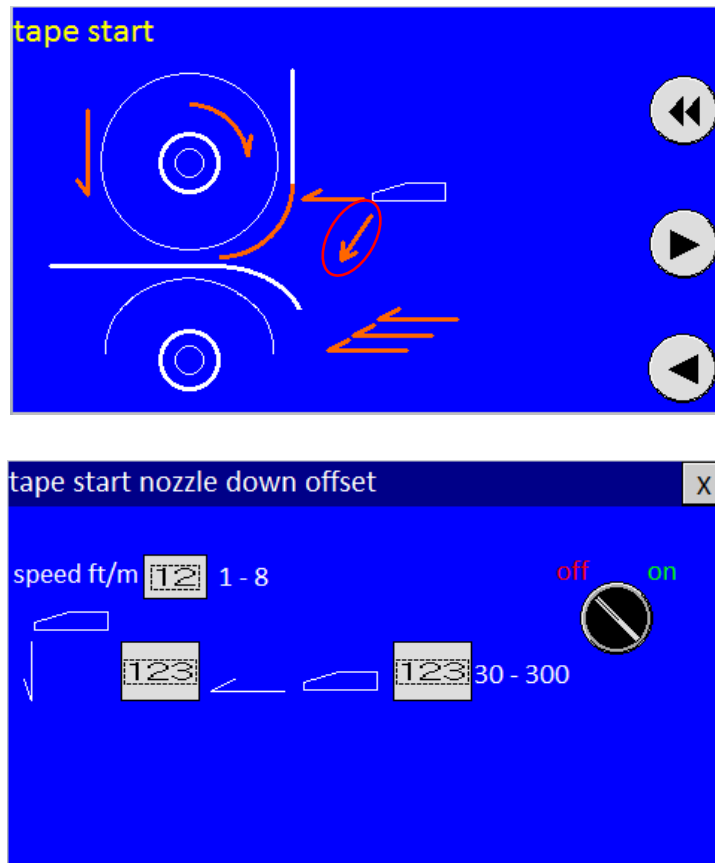

This setting controls the temporary operating position of the nozzle during a sealing immediately after a previous intermediate stop. The nozzle will start from this temporary position and gradually move back to the normal operating position. The v arrow setting controls the position of the temporary position in the down direction. The < arrow setting controls the position of the temporary position in the 'towards' roller direction. The speed setting controls the speed of nozzle returning to the normal operating position. Touch the ON/OFF switch to enable/ disable this function.

Appendix D . Tape Start, Tape Middle, Tape End Parameters

> Tape Start Program (cont.)

> Tape Start Program > roller soft start 1

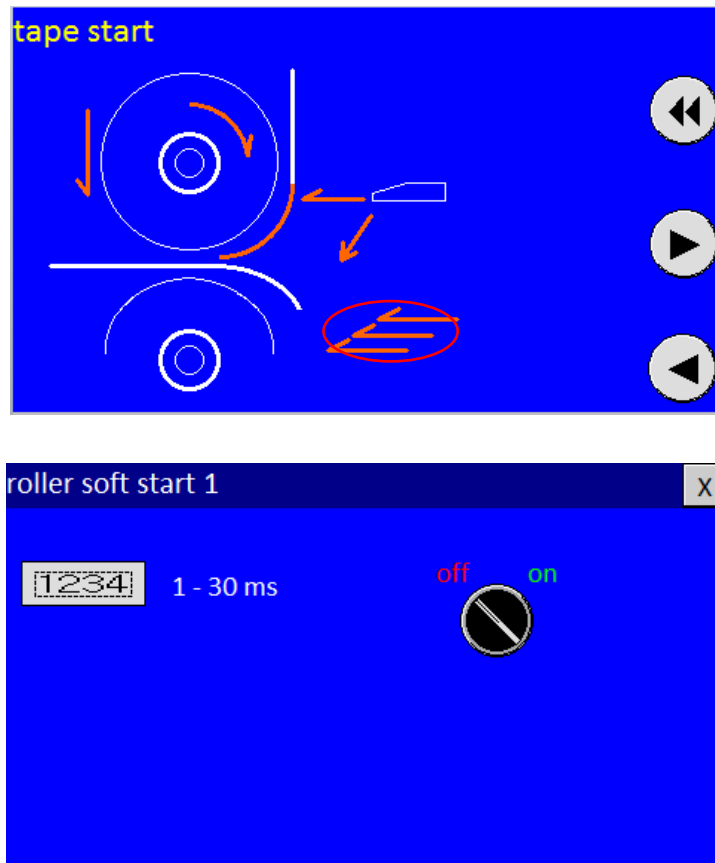

This setting controls the acceleration of the upper roller when starts to rotate until reaching the final speed. A smaller setting has a quicker acceleration and a larger setting has a slower acceleration. This is used to control the heat absorption of the tape start. Touch the ON/OFF button to enable/disable this function. If this function is 'off', the upper roller accelerates to full speed in the shortest time.

Appendix D . Tape Start, Tape Middle, Tape End Parameters

> Tape Middle Program

> Tape Middle Program > micro reverse

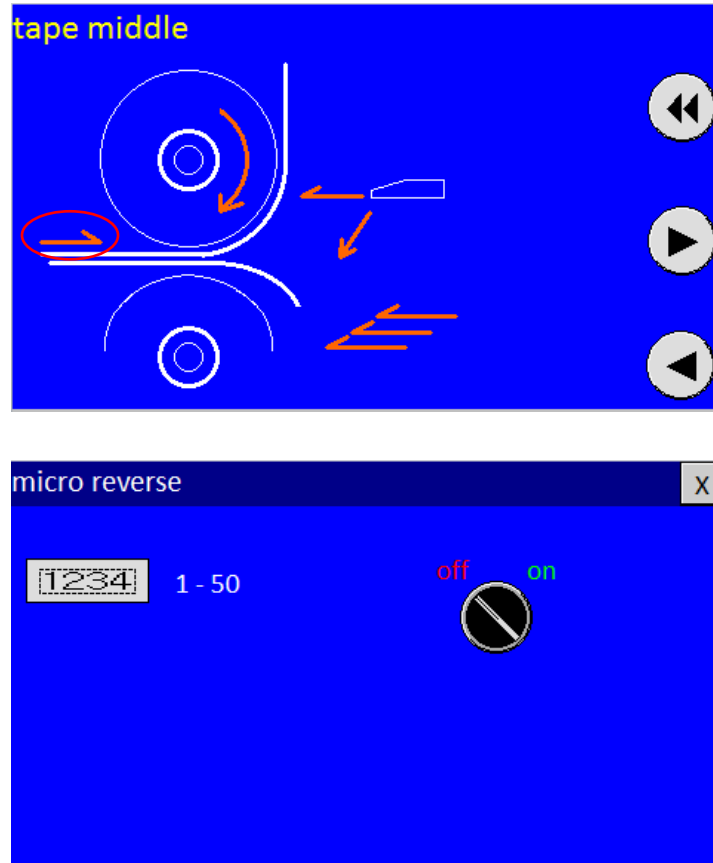

This setting controls the distance that the roller rotates backward during an intermediate stop while taping. A larger setting increases the angle that the upper roller rotates backward while a smaller settings decrease this angle. Touch the ON/OFF button to enable/disable this function. If this function is 'off', the roller does not rotate backward during a stop.

Appendix D . Tape Start, Tape Middle, Tape End Parameters

> Tape Middle Program (cont.)

> Tape Middle Program > motor start delay

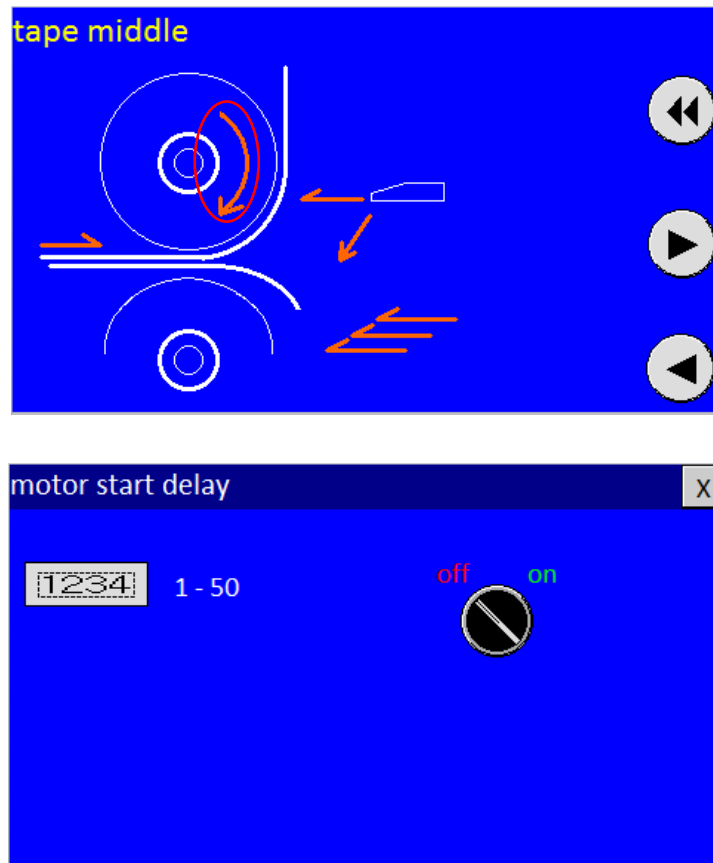

This setting controls the delay timing that the upper roller starts to rotate, after the nozzle has reached the normal operating position. A smaller setting means shorter delay hence making the upper roller start to rotate earlier, while a larger setting means longer delay hence making the upper roller start to rotate later. This is used to control the heat absorption of the tape middle. Touch the ON/OFF button to enable/disable this function. If this function is disabled, there is no delay so the upper roller rotates immediately after the nozzle arrived at the normal operating position.

Appendix D . Tape Start, Tape Middle, Tape End Parameters

> Tape Middle Program (cont.)

> Tape Middle Program > middle of tape nozzle penetration speed

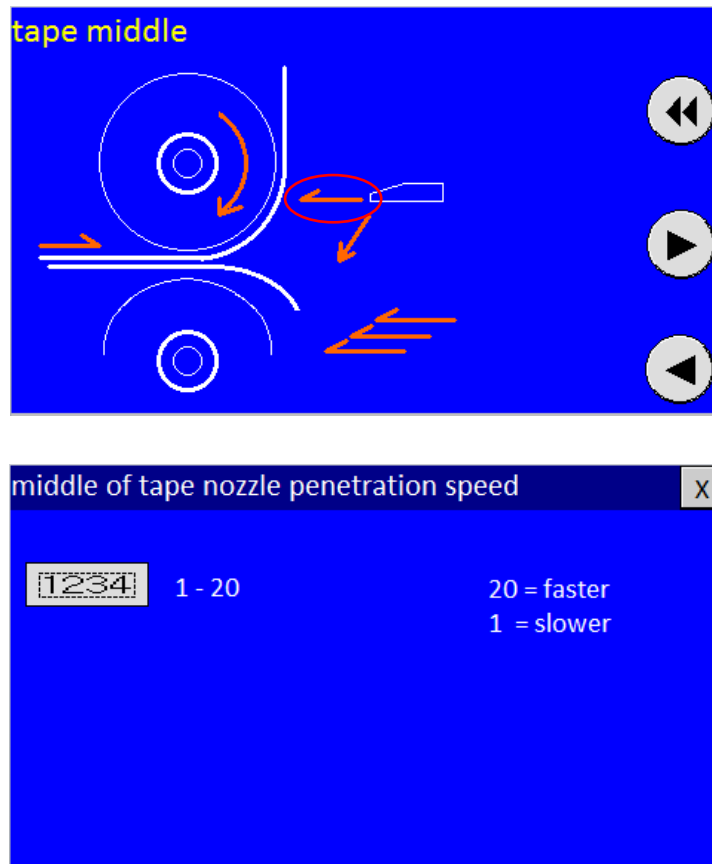

This setting controls the speed of nozzle moving towards the upper roller during a tape middle sealing. A smaller setting will increase the time it takes for the nozzle to move towards the upper roller during, but this will help providing a more evenly heated tape after an intermediate stop.

Appendix D . Tape Start, Tape Middle, Tape End Parameters

> Tape Middle Program (cont.)

> Tape Middle Program > tape middle nozzle down offset

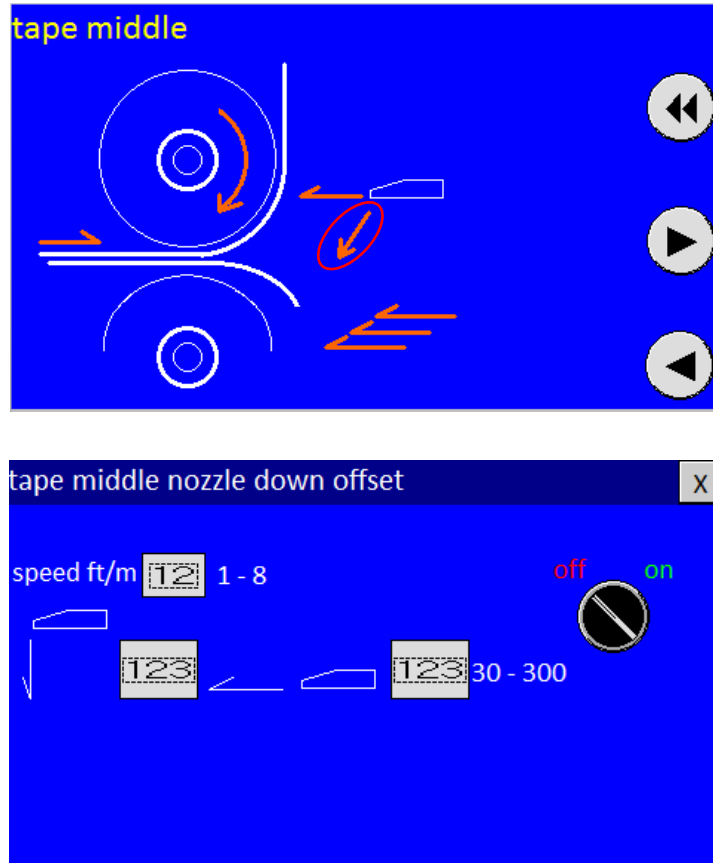

This setting controls the temporary operating position of the nozzle during a sealing immediately after a previous intermediate stop. The nozzle will start from this temporary position and gradually move back to the normal operating position. The v arrow setting controls the position of the temporary position in the down direction. The < arrow setting controls the position of the temporary position in the 'towards' roller direction. The speed setting controls the speed of nozzle returning to the normal operating position. Touch the ON/OFF switch to enable/ disable this function.

Appendix D . Tape Start, Tape Middle, Tape End Parameters

> Tape Middle Program (cont.)

> Tape Middle Program > roller soft start 2

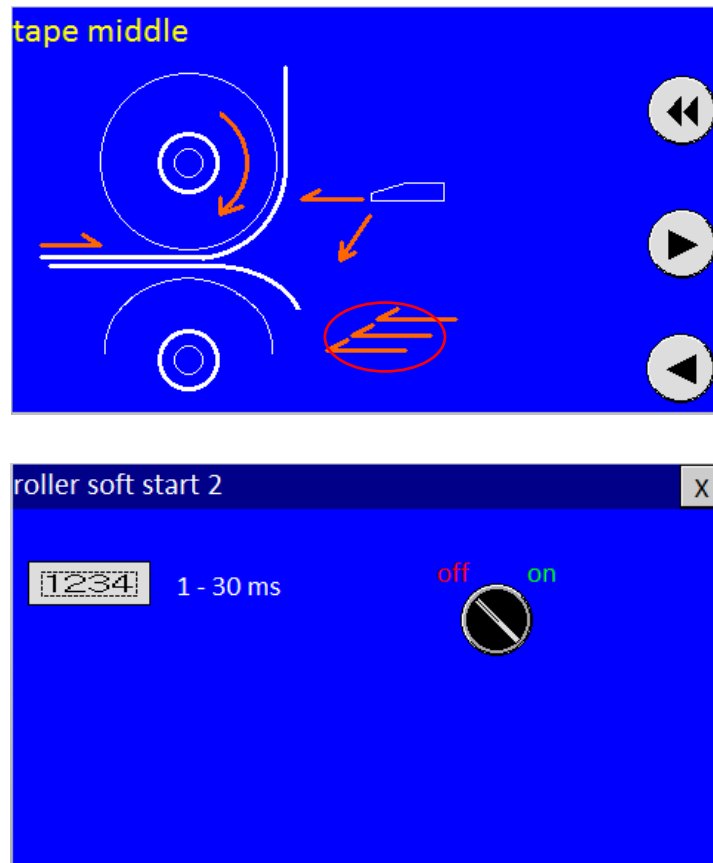

This setting controls the acceleration of the upper roller when starts to rotate until reaching the final speed. A smaller setting has a quicker acceleration and a larger setting has a slower acceleration. This is used to control the heat absorption of the start during tape middle. Touch the ON/OFF button to enable/disable this function. If this function is 'off', the upper roller accelerates to full speed in the shortest time.

Appendix D . Tape Start, Tape Middle, Tape End Parameters

> Tape End Program

> Tape End Program > after cut roller speed

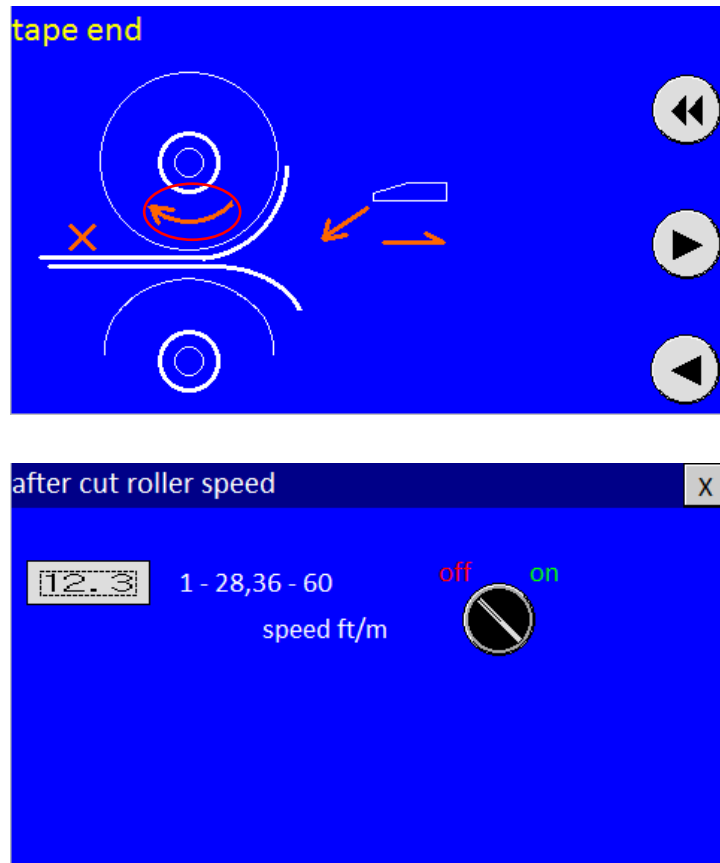

This setting controls the sealing speed after the tape is cut. A smaller than normal sealing speed setting will decrease the sealing speed after tape is cut. A larger than normal sealing speed setting will increase the sealing speed after tape is cut. This is used to control the heat absorption of the tape end. Touch the ON/OFF button to enable/disable this function. If this function is 'off', the sealing speed does not change after tape is cut.

Appendix D . Tape Start, Tape Middle, Tape End Parameters

> Tape End Program (cont.)

> Tape End Program > after cut nozzle retract

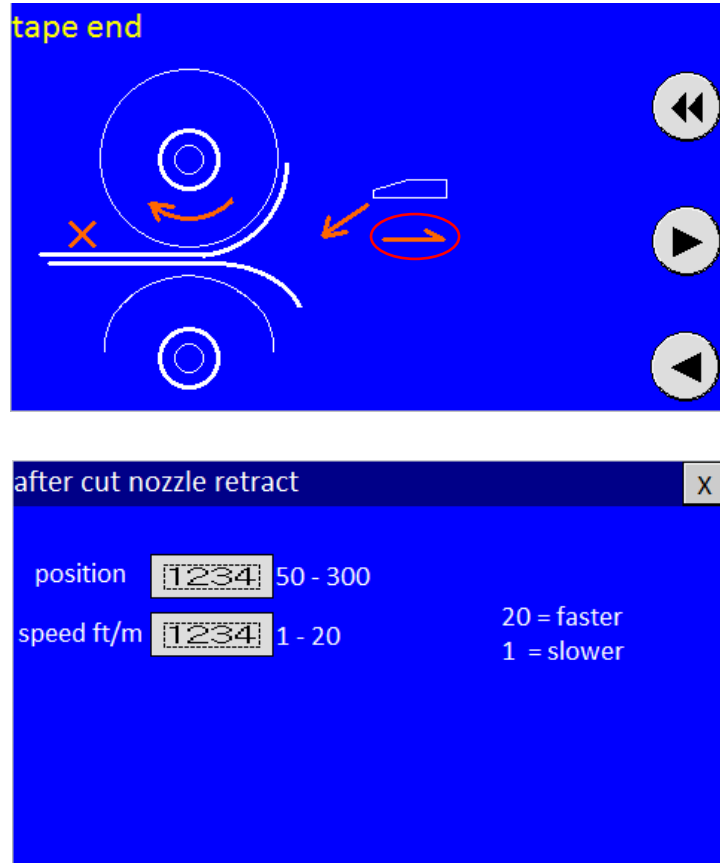

This setting controls the timing and the retract speed of the nozzle after tape is cut. Position is a reference number that is reset to 0 after tape is cut. With the upper roller continue to rotate after the cut, this reference number also increase. A smaller setting will make the nozzle retract quicker after the cut. A larger setting makes the nozzle retract later at tape end. The speed setting controls the speed of nozzle retract. This is used to control the heat absorption of the tape end.

Appendix D . Tape Start, Tape Middle, Tape End Parameters

> Tape End Program (cont.)

> Tape End Program > after cut roller stop position

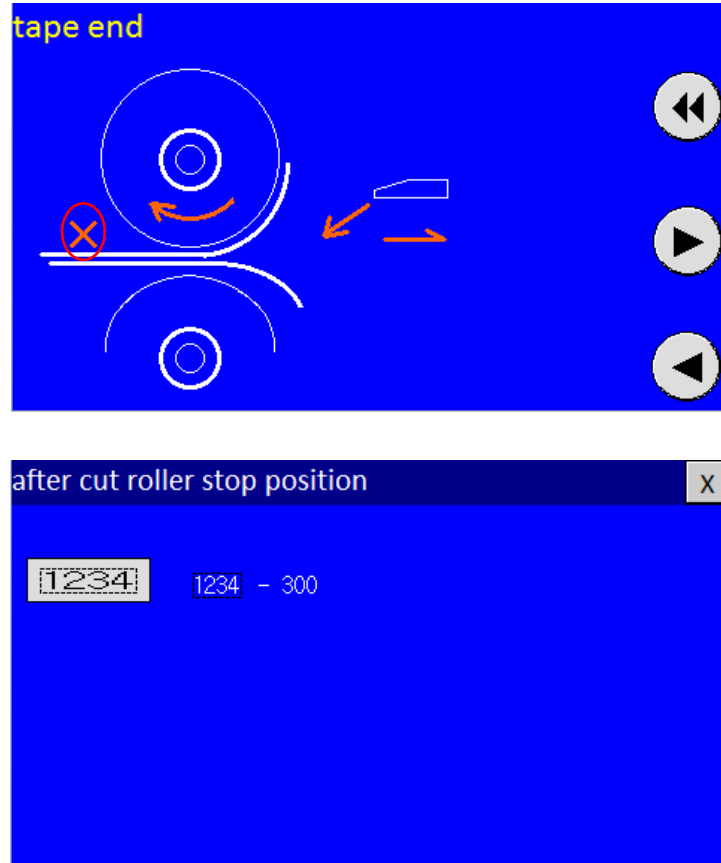

This setting controls the timing of the top roller stopping rotating after the tape is cut. Position is a reference number that is reset to 0 after tape is cut. With the upper roller continue to rotate after the cut, this reference number also increase. A smaller setting will make the roller stopping quicker after the cut. A larger setting makes the roller stops later after the cut.

Appendix D . Tape Start, Tape Middle, Tape End Parameters

> Tape End Program (cont.)

> Tape End Program > after cut nozzle new position

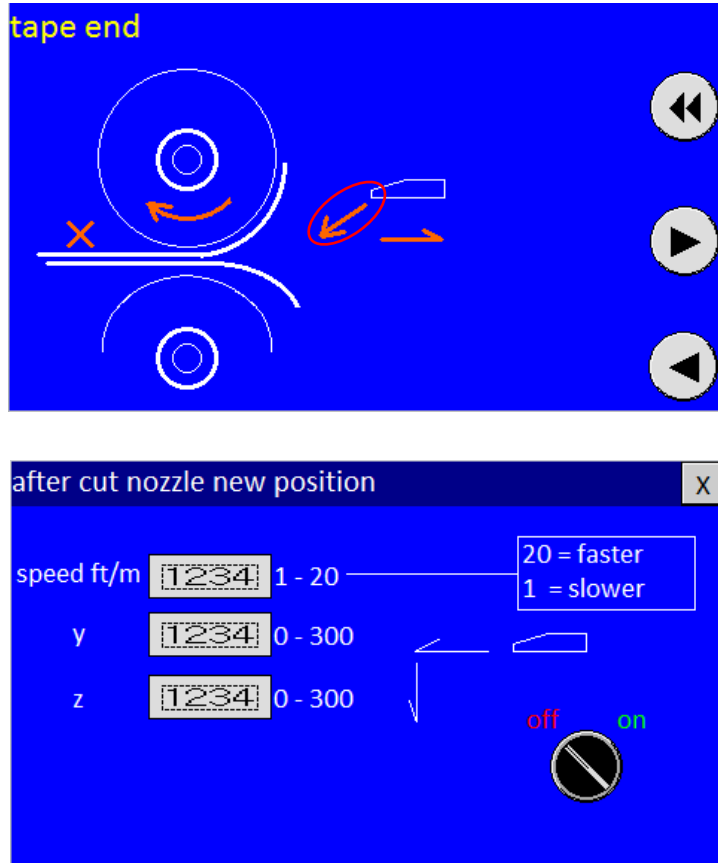

This setting controls the final new nozzle operating position after a tape cut. Immediate after a tape cut, the nozzle will gradually move to a new position. The speed controls the speed of migration from the normal operating position to the new position. The 'y' and 'z' settings controls the coordinate of this new position with respect to the normal operating position.