

JEUUX

Operating Manual

JEUUX-7510



This operating manual is valid for all machine versions,
models, and subclasses listed in section 2.02.

Reprinting, duplication, as well as translation of JEUX operating manuals
is only permitted with prior consent of Juki Central Europe and citation of proper reference.

JEUX

Ul. Poleczki 21
02-822 Warszawa

1	COMMENTS ABOUT THE MANUAL.....	6
2	SAFETY.....	7
2.1	Guidelines.....	7
2.2	General safety instructions.....	7
2.3	Safety symbols.....	8
2.4	Owner’s obligations.....	8
2.5	Operating personnel and specialized personnel.....	8
2.5.1	Operating personal.....	8
2.5.2	Specialized personnel.....	9
2.6	Warnings.....	9
3	PROPER USE.....	10
3.1	General.....	10
3.2	Machine versions.....	10
3.2.1	Flatbed version.....	10
4	TECHNICAL DATA	11
4.1	Technical data.....	11
5	DISPOSAL OF THE MACHINE	12
5.1	Disposal of the machine	12
6	TRANSPORT, PACKAGING, AND STORAGE.....	13
6.1	Transport to the customer’s facility	13
6.2	Transport within the customer’s facilities	13
6.3	Disposal of the packaging	13
6.4	Storage	13
7	WORK SYMBOLS	14
7.1	Work symbols.....	14

8	HARDWARE.....	15
8.1	Model-dependent components.....	15
8.2	Connection / replacing the pedal	16
9	ADJUSTMENT	17
9.1	Adjustment instructions	17
9.2	Tools, gauges and other resources	17
10	MAINTENANCE AND CARE	18
10.1	Daily or weekly inspection:.....	18
10.2	Monthly to quarterly inspection:.....	18
10.3	Cleaning the stainless steel cladding:	19
11	SET-UP AND FIRST START –UP.....	20
11.1	Set-up.....	20
11.2	Initial startup	21
11.3	Switching the machine on/off.....	22
12	MACHINE OPERATING	23
12.1	Symbols	23
12.2	Main view	24
12.3	Setup Parameter.....	24
12.4	Anvil Selection	26
12.4.1	Mount Wheel.....	27
12.4.2	Calibrate new wheel	29
12.5	Start-/Stop Parameter	30
12.6	Gap-Control	30
12.7	Approach	31
12.7.1	Pedal	31
12.7.2	Ultrasonic Configuration.....	32
12.7.3	Network Setting.....	32
12.7.4	Remote Support.....	33
12.7.5	General	34
12.7.6	Machine-Activation	34
12.7.7	Language-Settings.....	35
12.7.8	Factory-Settings.....	36
12.7.9	Info.....	37

12.8	Potential Signal	38
12.8.1	Nucleus Device-error	38
12.8.2	Nucleus Exception Raised	40
13	WELDING	41
13.1	Welding principle.....	41
13.2	Determining welding parameters	42
13.2.1	Welding.....	42
13.2.2	Separation welding	44

1 Comments about the Manual

Unless expressly indicated otherwise, the descriptions in this manual refer to the software of your JEUX-7510, and thus can be selected via the touch-sensitive monitor.

Figures showing screenshots of the software are provided frequently in this manual to present the function as efficiently as possible. These figures contain numbered markings in the format [x/y] that are referred to in the description. The first number indicates the number of the figure, the second number refers to a marker in this figure.

Please note that the graphic illustrations in this manual can vary in whole or in part to your machine software, due to updates for example. In this case you will always find current manuals on our website. However in this regard, note that due to the modular design and thus the wide range of customization possibilities of our machines, deviations can occur between the illustrations of the machine provided in the manual as examples, and your configuration.

Consequently the version number of the installed software is the deciding criterion for selecting the optimally suited manual. Section 12 describes how to read the version numbers.

2 Safety

2.1 Guidelines

The machine has been built in accordance with the European Directives specified in the declaration of conformity or manufacturer's declaration.

In addition to this operating manual also into consideration, legal regulations, other regulations and statutory regulations – including those of the owner's country – and valid environmental protection regulations into -consideration!

The locally valid regulations issued by the employer's liability association or other supervisory authorities must always be taken into consideration.

2.2 General safety instructions

- The machine should only be operated by appropriately instructed operating personnel after they have read the -associated operating manual.
- Warnings and safety instructions affixed to the machine must be complied with!
- Do not operate the machine for any purpose other than its intended purpose, and do not operate the machine without the associated protective devices; in this regard comply with all applicable safety regulations.
- When changing the anvil wheel, when leaving the workstation, and when performing maintenance work, the -machine must be disconnected from the power supply by activating the main switch or by unplugging the power plug.
- Daily maintenance work should only be performed by appropriately instructed personnel.
- Always disconnect the machine from mains supply when performing maintenance or repair work on devices powered by servo motors! Exceptions are only permitted for adjustment work and function tests performed by appropriately trained specialized personnel.
- Repair tasks, as well as special maintenance tasks should only be performed by specialized personnel or appropriately instructed persons.
- Work on electrical systems should only be performed by qualified electricians.
- Do not work on live parts and devices. The EN 50110 regulations govern the exceptions.
- Conversions or modifications of the machine should only be undertaken in compliance with all applicable safety regulations
- Only use the spare parts approved by JUKI for repairs! We explicitly state that original spare parts and accessories not delivered by JUKI have not been tested and approved by JUKI. Consequently installation / and or use of such products can negatively change design-specified characteristics of the machine.
We assume no liability whatsoever for damage that occurs due to the use of non-original spare parts.

2.3 Safety symbols



Danger point!
Points that require special attention.



Danger of crushing hand injuries!



Danger of burn injuries due to hot surface!



Life-threatening danger due to electrical shock.

2.4 Owner's obligations

- This manual is a component of the machine and must be available to operating personnel at all times. The operating manual must be read prior to commissioning.
- Operating personnel and specialized personnel must be instructed concerning the protective devices of the machine as well as in safe work methods.
- The owner is obligated to operate the device only in problem-free condition.
- The owner must ensure that safety devices are not removed or rendered inoperable.
- The owner must ensure that only authorized personnel work on the machine.

2.5 Operating personnel and specialized personnel

2.5.1 Operating personal

Operating personnel are personnel who are responsible for charging, operating, and cleaning the machine, as well as for fault correction in the welding area.

Operating personnel are under obligation to comply with the following points:

- The safety instructions specified in the operating manual must be complied with for all tasks!
- Refrain from any manner of work that impairs the safety on the machine!
- Wear tight-fitting clothing. Do not wear jewelry, such as chains and rings!
- Ensure that only authorized persons are in the danger zone of the machine.

- Changes that occur on the machine that impair safety must be reported to the owner immediately!

2.5.2 Specialized personnel

Specialized personnel are personnel with technical training in the areas of electronics and mechanical engineering.

They are responsible for lubricating, maintaining, repairing, and adjusting the machine.

Specialized personnel are under obligation to comply with the following points:

- The safety instructions specified in the operating manual must be complied with for all tasks!
- The main switch must be switched off and safeguarded against being switched on again prior to
- Starting adjustment tasks and repair tasks.
- Work on live parts and devices is not permitted!
- The EN 50110 regulations govern the exceptions.
- The protective covers must be re-attached after performing repair and maintenance tasks!

2.6 Warnings



A work area of 1m in front of and behind the machine must be kept free so that unobstructed access is possible at any time.



Do not operate the free-arm, column, and downward arm versions of the machine without finger guard 1! Danger of crushing injuries if fingers are caught between transport roller 3 and 4!



Do not operate the flatbed versions of the machine without finger guard 5! Danger of crushing if fingers are drawn in!



Do not operate the free-arm versions of the machine without cover 2! Danger of crushing injuries if fingers are caught between transport roller 3 and 4!



Do not grasp transport roller 3 during machine travel! There is a danger of burn injuries due to the heat generating surface!



When operating ensure that your head is more than 30 cm away from transport roller 3! Danger of hearing damage due to ultrasonic radiation!

3 Proper use

3.1 General

All JEUX-7510 machines are used to continuously weld thin, thermoplastic materials such as fleece, felt, fabric, or knitted fabrics via ultrasound. The special application areas of the specific versions are described below [see section 3.2. Machine versions].



Any use that is not approved by the manufacturer is considered to be improper use!
The manufacturer is not liable for damage due to improper use! Proper use also includes compliance with the operating, maintenance, adjustment, and repair measures prescribed by the manufacturer!



All descriptions in this operating manual refer to the free-arm version of the welding machine. If necessary, reference is made to deviating work steps for the other versions.

3.2 Machine versions

3.2.1 Flatbed version

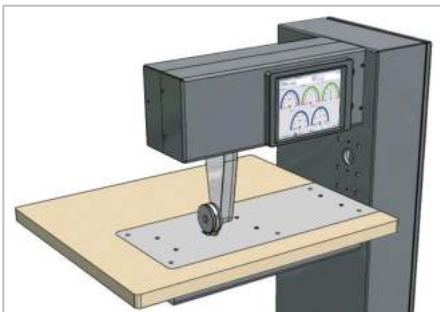

The flatbed version is used particularly for welding two flat parts. This can involve overlap seams, peel seams, topstitch seams, or hems. The processing possibilities correspond to the processing possibilities of a typical “rapid-action” sewing machine.

For the flatbed version the upper transport wheel is the sonotrode.

4 Technical data

4.1 Technical data

Dimensions and weights:

Depth [mm]	Flatbed
Width [mm]	approx. 600
Breite [mm]	approx. 925
Height [mm]	approx. 1180
Weight [kg]	approx. 120

Passage width: 400 mm

Passage under the drive rollers: 25 mm

Line voltage: 230 V \pm 10%, 50/60 Hz, phase

Power consumption: 800 VA

Fusing: 1 x 16 A, time lag

Weld pressure: 450 N

Welding power: 400 W

Welding speed (drive dependent):

Standard motor: max. 12 m/min

Seam width: max. 10 mm

Noise specification: LpA < 70 dB(A)

Emission sound pressure level at the workplace

(Noise measurement in accordance with DIN 45 635-48-A-1, ISO 11204, ISO 3744, ISO 4871)

5 Disposal of the machine

5.1 Disposal of the machine

- It is the customer's obligation to properly dispose of the machine.
- The materials used to construct the machine are steel, aluminum, brass, and various plastics. The electrical equipment is made of plastic and copper.
- The machine must be disposed of in accordance with local applicable environmental protection regulations; it may be necessary to commission a special company in this regard.



Ensure that parts on which lubricants adhere are disposed of separately in accordance with local environmental regulations!

6 Transport, packaging, and storage

6.1 Transport to the customer's facility

The machines are delivered completely packed.

6.2 Transport within the customer's facilities

The manufacturer assumes no liability for transport within the customer's facilities or to the specific installation sites. Ensure that the machines are only transported in vertical position.

6.3 Disposal of the packaging

The packaging of this machine consists of paper, cardboard, and VCE fleece. It is the customer's obligation to properly dispose of packaging.

6.4 Storage

If the machine will not be used it can be stored for up to 6 months. After 6 months it should be protected from dirt and moisture.

For a longer period of machine storage the individual parts, particularly the sliding surfaces, must be safeguarded against corrosion, e.g. with a film of oil.

7 Work symbols

7.1 Work symbols

In this manual activities to be executed or important information is emphasized with symbols. The symbols used have the following meaning:



Note, information



Cleaning & care



Lubrication



Service, repair, adjustment, maintenance (activity that should only be executed by specialized personnel)

8 Hardware

8.1 Model-dependent components

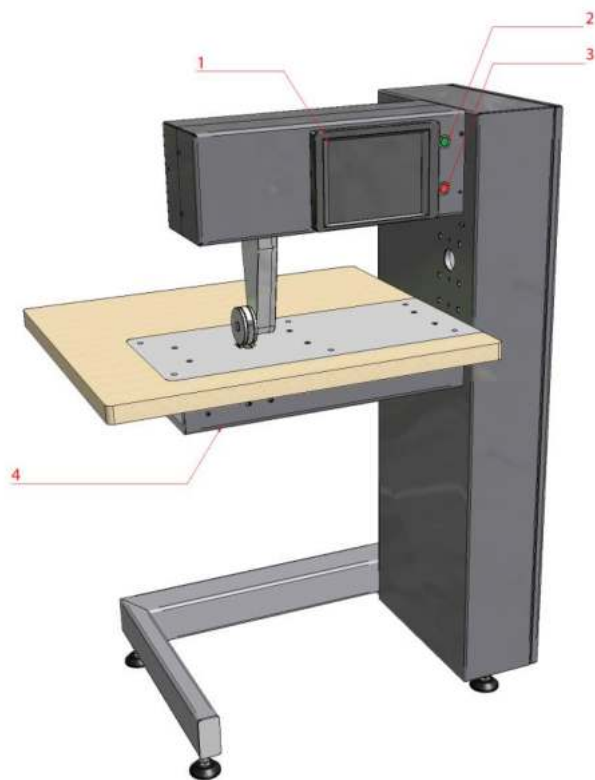

1. Touch screen
2. On/off switch
3. Generator on/off

Fig: Control elements

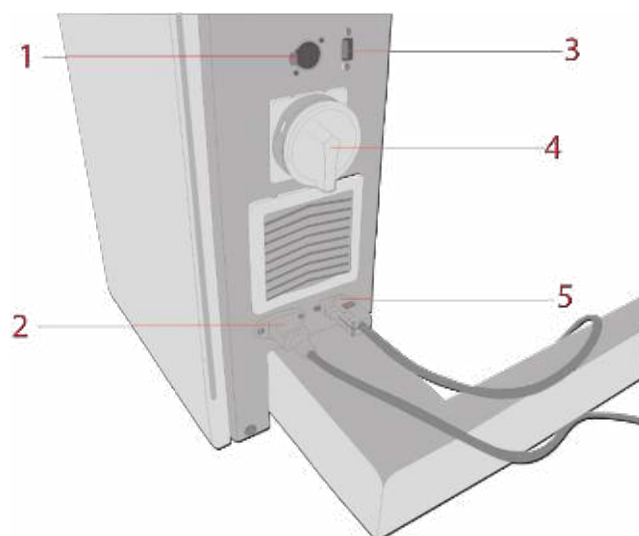

1. LAN
2. Power (cold devices)
3. USB
4. Main switch
5. Pedal

Fig.: Connections (rear of the machine)

8.2 Connection / replacing the pedal

If necessary unplug the mounting of the pedal cable [see Fig. Connections], remove the connected pedal and -connect the desired pedal. To conclude re-attach the cable with the fixture provided for this purpose.

Note: You must explicitly set the pedal type; see point [12.5.1] for instructions on how to do this.

9 Adjustment

9.1 Adjustment instructions

All the tasks described below presuppose a completely assembled machine and should only be executed by -appropriately trained specialized personnel. Machine covers that must be unscrewed and screwed on again for control and adjustment work are not mentioned in the text.

The sequence of the following sections follows the practical work sequence of a machine that must be completely adjusted. If only individual work steps are specifically executed then the instructions in the preceding and following sections must also be complied with.

The screws and nuts cited in parentheses (example: **screws (2)**) are fastenings of machine parts that must be -loosened prior to adjustment and re-tightened after adjustment.



If not otherwise specified the machine must be disconnected from the power supply by switching off on the main switch or by pulling out the power plug. Hazard posed by unintentional machine startup!

9.2 Tools, gauges and other resources

- 1 set of screwdrivers with blade widths from 2 to 10 mm
- 1 set of screwdrivers with blade widths from 7 to 17 mm
- 1 set of Allen keys from 1.3 mm to 10 mm
- 1 pin wrench for 2-hole nuts for the transport wheel

10 Maintenance and care

All moving parts of the JEUX-7510 are maintenance-free or of low maintenance.

However certain cleaning and maintenance tasks may be necessary depending on the type of implementation, installation site, and exterior temperature:

10.1 Daily or weekly inspection:

Remove welding residues on the sonotrode and anvil wheel unit with a dry cloth.

Particularly in the lower boom arm of the machine (flatbed version), or in the housings of the free-arm variants, material remnants, fine fibers, or dust residues can collect that can block the gear motor and drive elements. These residues must be removed. Vacuuming is better than blowing out, as in this case the contaminants do not settle at other points.

- Switch off the ultrasound; move sonotrode or anvil column into the upper position.
- Unscrew the cover caps and covers of the free arms (it may be necessary to remove puller wheels and anvil wheels)
- Allow the drive to slowly run forward incrementally and intermittently vacuum off the residual contamination (attention: Do not pinch the suction nozzle).
- Listen for grinding and blocking noises

10.2 Monthly to quarterly inspection:

- Switch off the main switch or unplug the power supply plug.
- Unscrew the front housing cover (4 small M4 screws), unplug the monitor, and buttons "PC on", "US on" plug-in connectors.
- Carefully place the housing part with monitor to the side.
- Vacuum out the upper boom, remove any residual contamination, and check the eccentric for ease of movement.
- Clean and lightly grease anvil wheel shaft as well as side surfaces of the anvil wheels and puller wheels.
- Open the control cabinet, carefully vacuum off the contaminant residues, check all plug-in connections for firm seat.
- Clean the filter mats of the cabinet fans.
- Re-mount the housing lid, check the plug-in connections for firm seat.

10.3 Cleaning the stainless steel cladding:

- Clean the housing parts with a soft cloth, do not scratch or abrade.
- If necessary use an off-the-shelf cleaning fluid for stainless steel sheets.



Exercise extreme caution when cleaning the touch screen; only use a soft cleaning cloth, do not use any scratching or abrasive agents.

11 Set-up and first start –up

After unpacking, check the machine for transport damage. If there is damage, notify the transport company and the responsible JEUX representative.



Only qualified personnel should set-up and commission the machine! Strictly comply with all - applicable safety guidelines in this regard.

11.1 Set-up

Suitable power supply connections must be available at the set-up site (see section 3 Technical data).

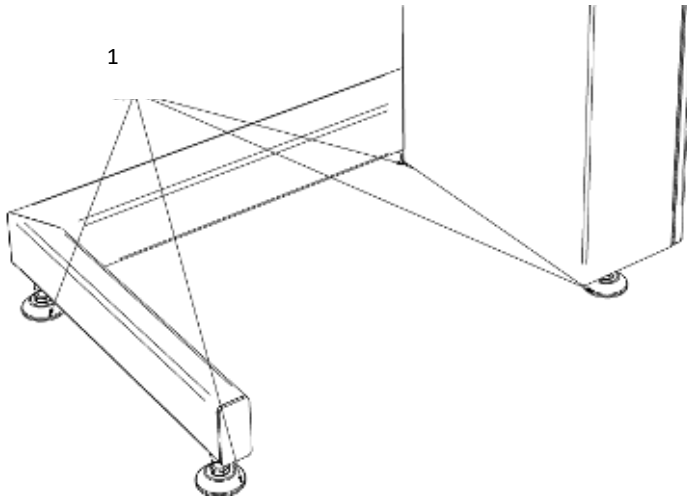

- Slide the machine off of the transport pallet.
- Place the machine at a slight diagonal angle and screw in the feet 1 that are included in the accessories, so that the machine stands horizontally.



Do not tilt the machine at too much of a diagonal incline! There is danger of tipping due to the machine's high center of gravity!

- Connect the plug-in connection 2 of the pedal 3.

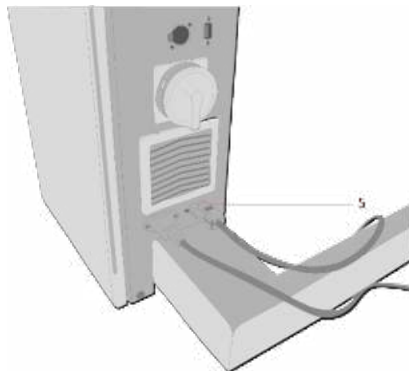

4. Pedal connection

11.2 Initial startup

- Check the machine, particularly the electrical lines, for possible damage.
- Thoroughly clean the machine, see section 8, maintenance.
- Connect the machine to the electrical power, in this process have specialists check whether the machine should be operated with the existing supply voltage and that the machine is properly connected.



If the supply voltage does not agree with the machine specifications do not place the machine in service under any circumstances.



The machine should only be connected to a grounded socket!

11.3 Switching the machine on/off

- Establish the power supply to the device.
- Switch the device on by briefly pressing the power switch one time.
- The device will start. Wait until the following view is displayed:



- The software is operated exclusively via the touch-sensitive monitor, there are no additional control elements such as mouse or keyboard.

12 Machine operating

12.1 Symbols



Use this button to go one step back



Machine Configuration



Switch on



Switch off



Cloud

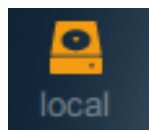

Information in the machine



Stick



Calibration



information

12.2 Main view

- This is the starting screen



12.3 Setup Parameter



- Here you change the parameters: power, pressure and speed.
- For change the parameter, turn the blue circle to the right to increase the setting, or to the left to decrease it.

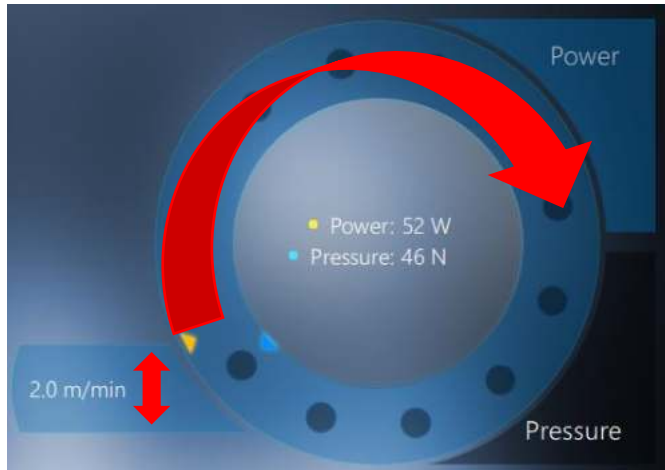

- **Pressure**
Shows the pressure exerted by the machine on the processed material, in percent. Values that are too low can have a negative effect on the welding result.
- **Power**
The power displayed here corresponds to the thermal output given off to the material in watt.
- **Amplitude**
Amplitude of the sonotrode in percent; insufficient amplitude and excessive amplitude have negative effects on fusion, as in these cases the power can no longer be adequately controlled. [--> autom. pressure control]
- **Speed**
Indicates the speed in meters/minute with which the material is directed past the sonotrode.

12.4 Anvil Selection

- For change the anvil wheel, press



and select the desired wheel.

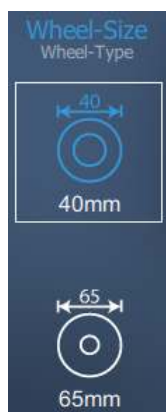

- Please select the diameter of the desired anvil wheel.

- Then select the appropriate picture with the corresponding wheel number and confirm with



12.4.1 Mount Wheel

If you use the screw nut, use this keys to loose the wheel.



Use key 1 to fix the red area.

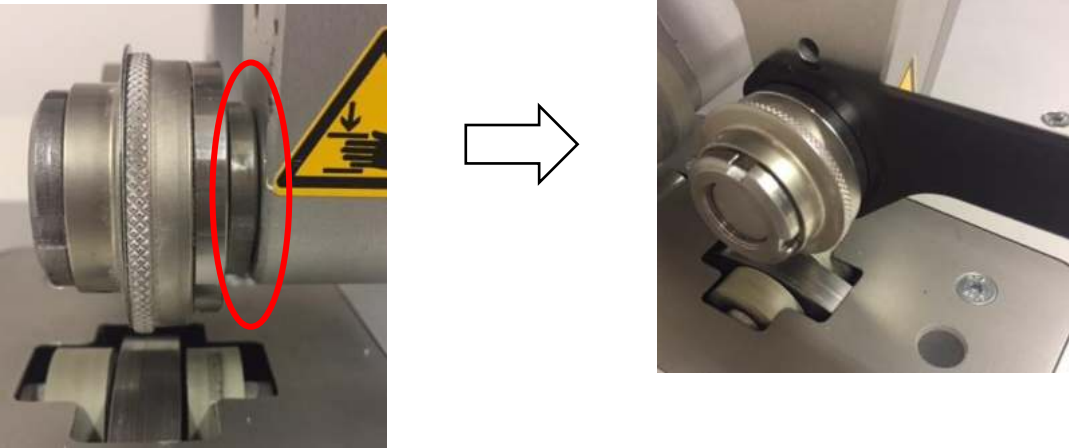

Use key 2 to open the screw nut.

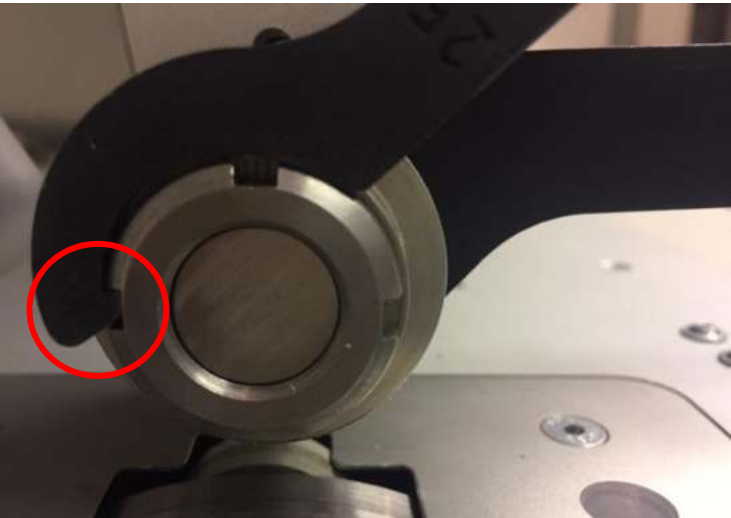

Use the keys as described with the red arrows.

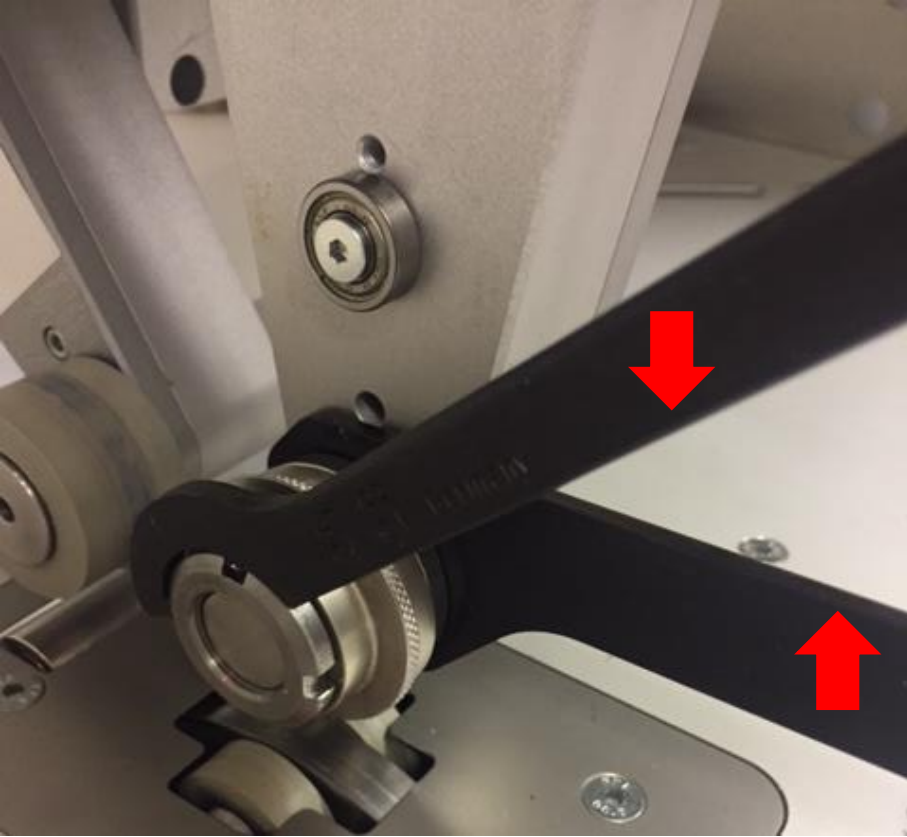

12.4.2 Calibrate new wheel

- If you have never used the anvil wheel before, calibrate it with the button

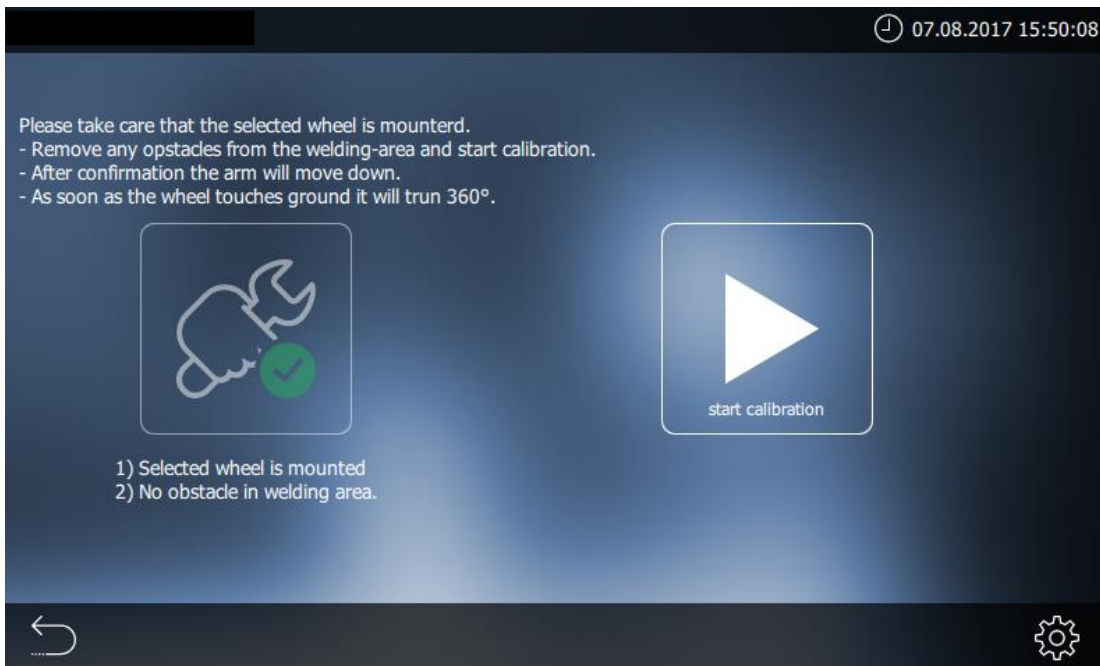

- The symbol appears green as soon as the wheel has already been used and has already been calibrated.

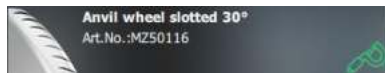

- Than you don't need to calibrate, so you can choose



and mounted the wheel.

12.5 Start-/Stop Parameter



- For a perfect transition, you can optimize the performance and speed of starting and stopping.



12.6 Gap-Control



- The gap between anvil wheel and sonotrode can be adjusted individually.



12.7 Approach



12.7.1 Pedal



- Use of the Pedal



When you press the pedal for a short time to the red marked area, the machine arm with the welding wheel, will raise or goes down.



Press the pedal forwards into the green area, the sonotrode and the anvil wheel begin to rotate and the welding process begins. You stop the welding process as soon as you stop the forward movement of the pedal.

In order to realize a good welding result, the right operation of the pedal is requirement. Important is the use of a clean start and stop chapter. A different operation, can lead to unwanted welding results, as well as to unforeseen machine activities.

- After changing the pedal type or the setpoint device, the pedal must be recalibrated.

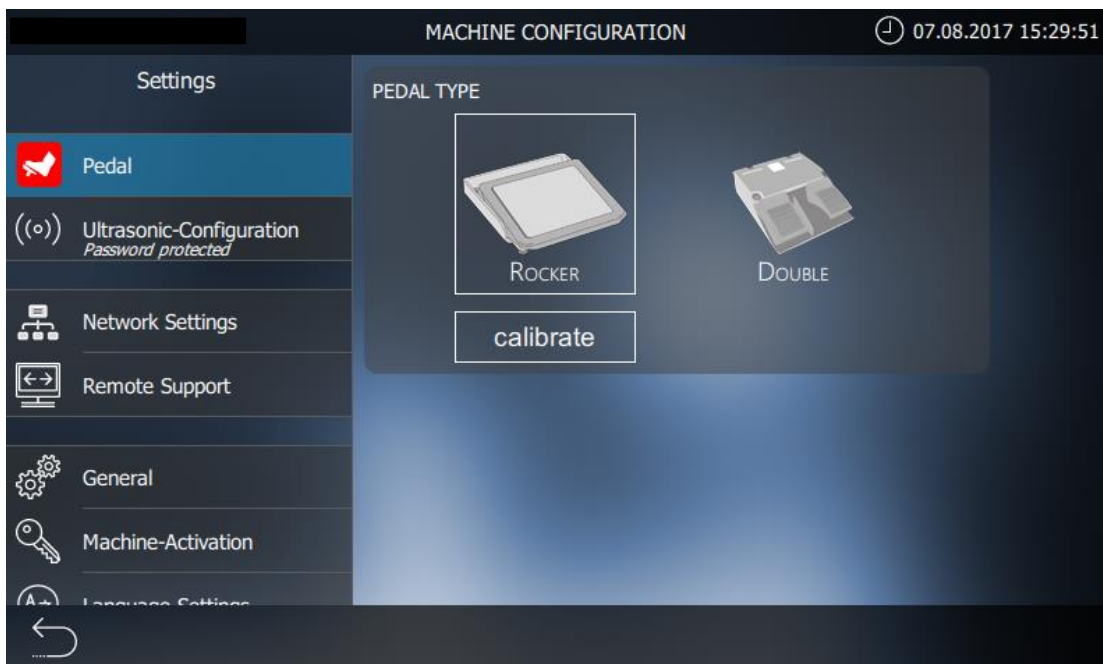

12.7.2 Ultrasonic Configuration

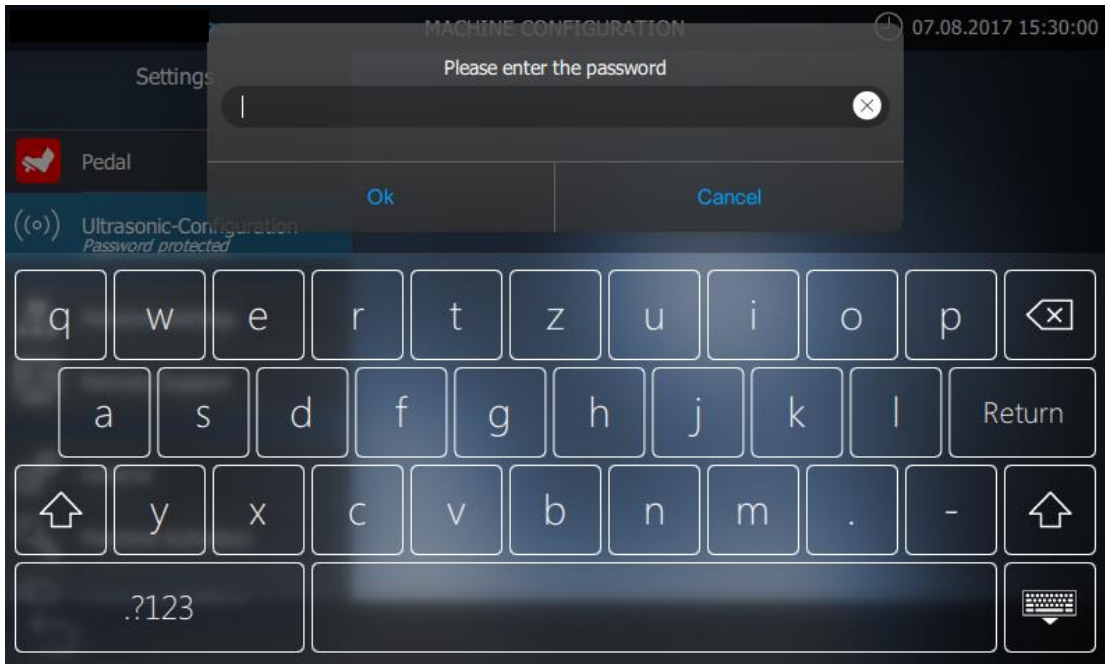

12.7.3 Network Setting

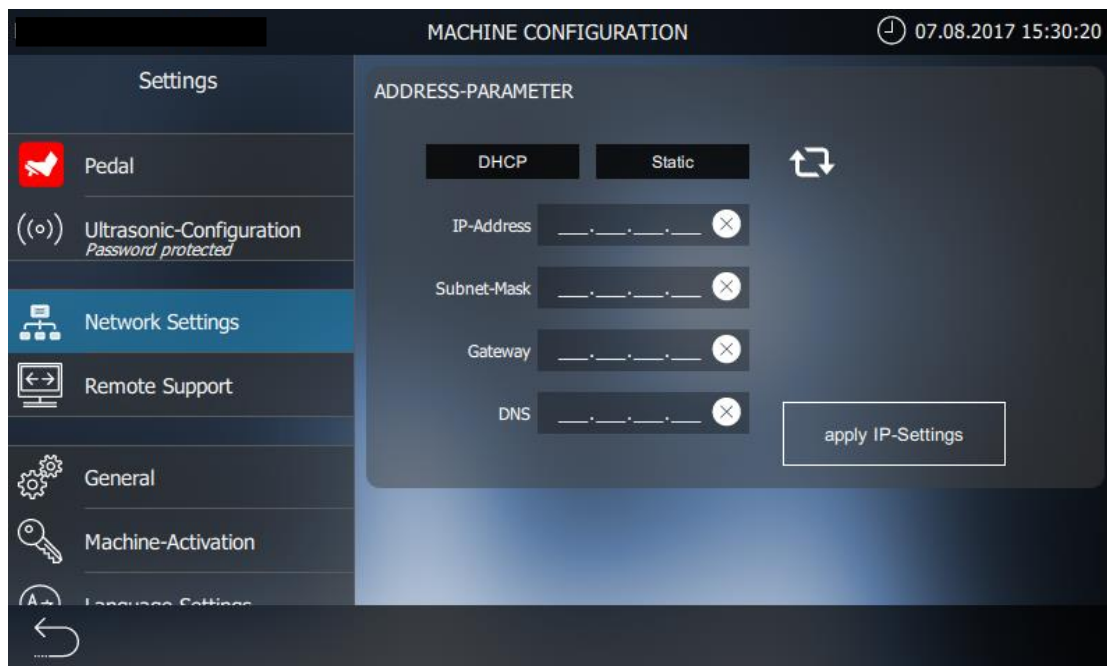

12.7.4 Remote Support



- This function is use for a remote maintenance.

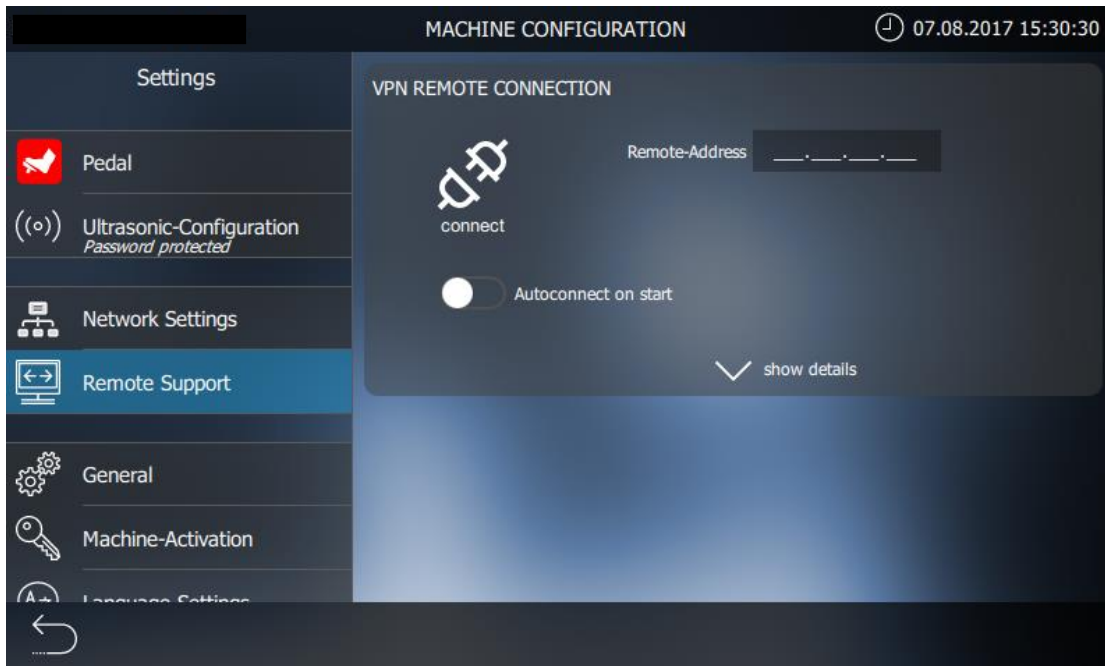

12.7.5 General



- Enter a machine password to use the machine.



12.7.6 Machine-Activation



- Enter your Code to activate and use the machine.

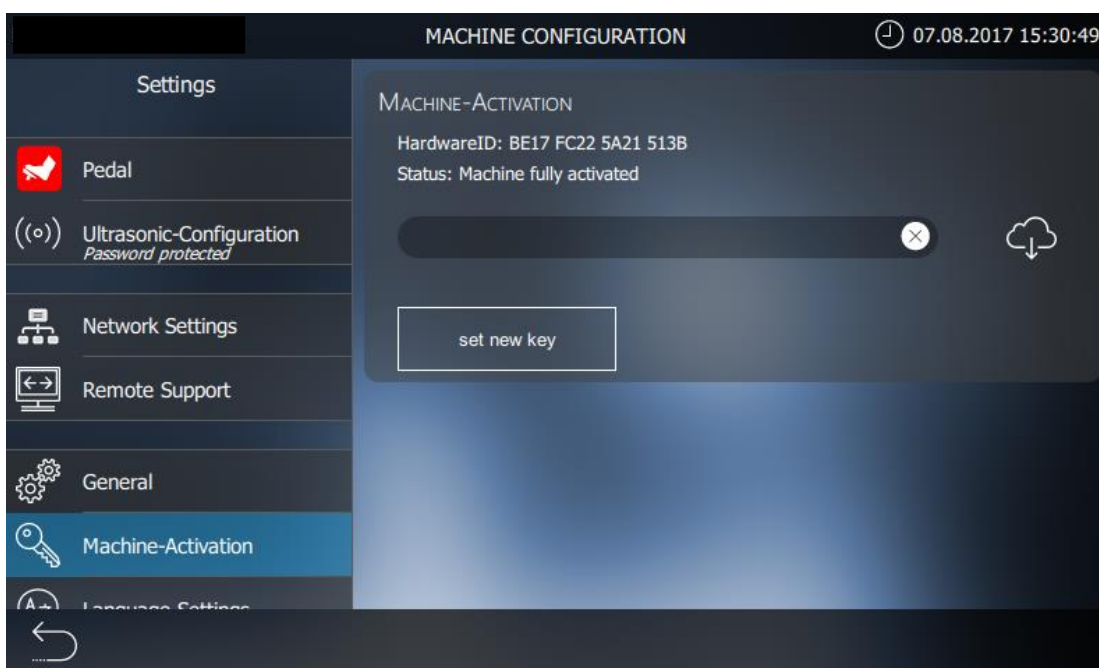

12.7.7 Language-Settings



- Here you can select the application-language.
- If needed, you can switch the Numeric-Format from
mm → feet
m/min → ft/min
N → lb
- Please restart the machine, when you change the language.



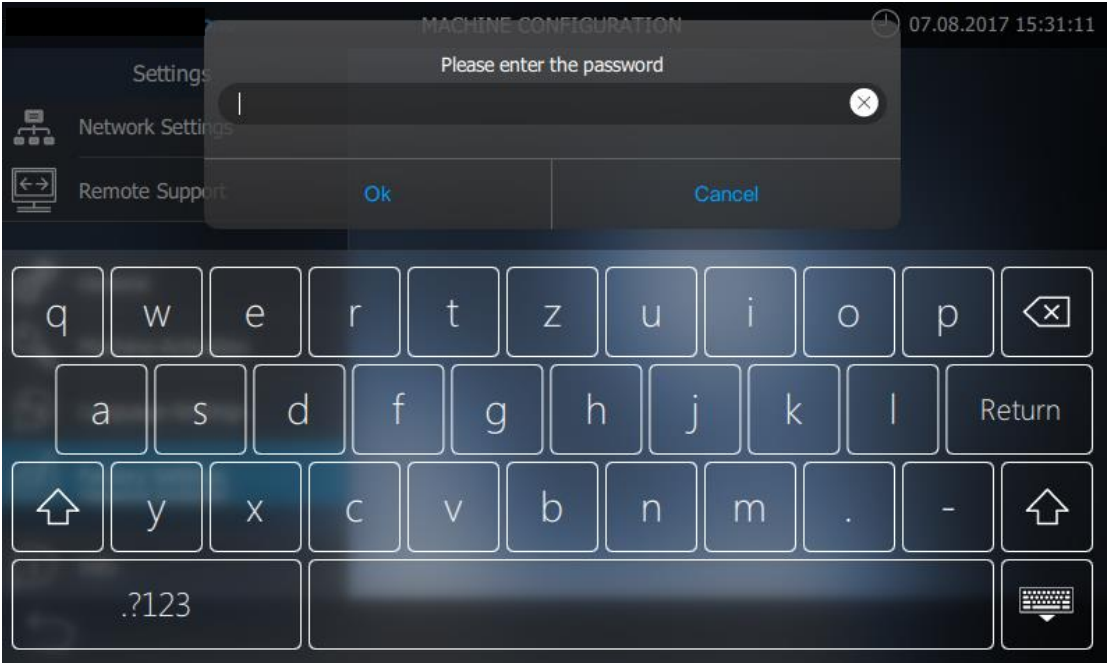



- Here you get information about the installed hardware, version information and about the machine usage.

MACHINE CONFIGURATION 07.08.2017 15:31:22

Settings

- Network Settings
- Remote Support
- General
- Machine-Activation
- Language-Settings
- Factory Settings
Password protected
- Info**

VERSION INFORMATION

Application	0.8.112
ahedNetLib	1.0.0.0
ethLib	0.9.9.2
Generator OS	not available
Generator Firmware	not available

MACHINE USAGE

Uptime	00:17:42
Sonic-ON Time	00:00:00
Sonic-Cycles	0
Distance welded	0,00 m

Copyright (C) 2016 Nucleus GmbH

12.8 Potential Signal

12.8.1 Nucleus Device-error

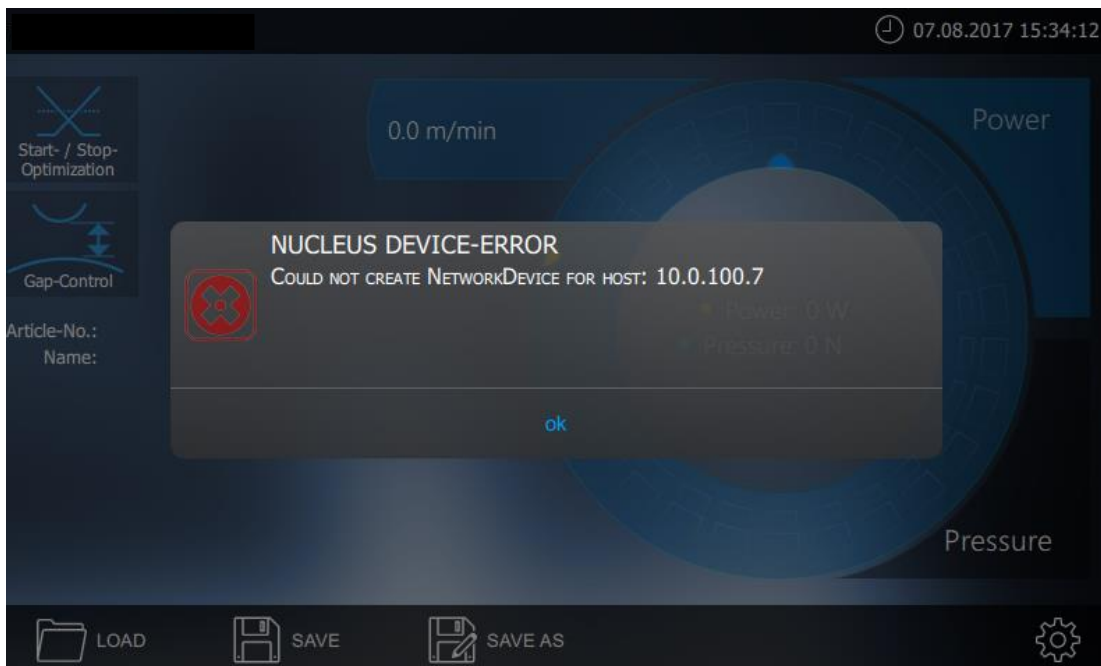

Possible causes:

- Please check Power – Supply

CHECK POWER-SUPPLY - good example



CHECK POWER-SUPPLY - bad example (no earth-connection)



12.8.2 Exception Raised

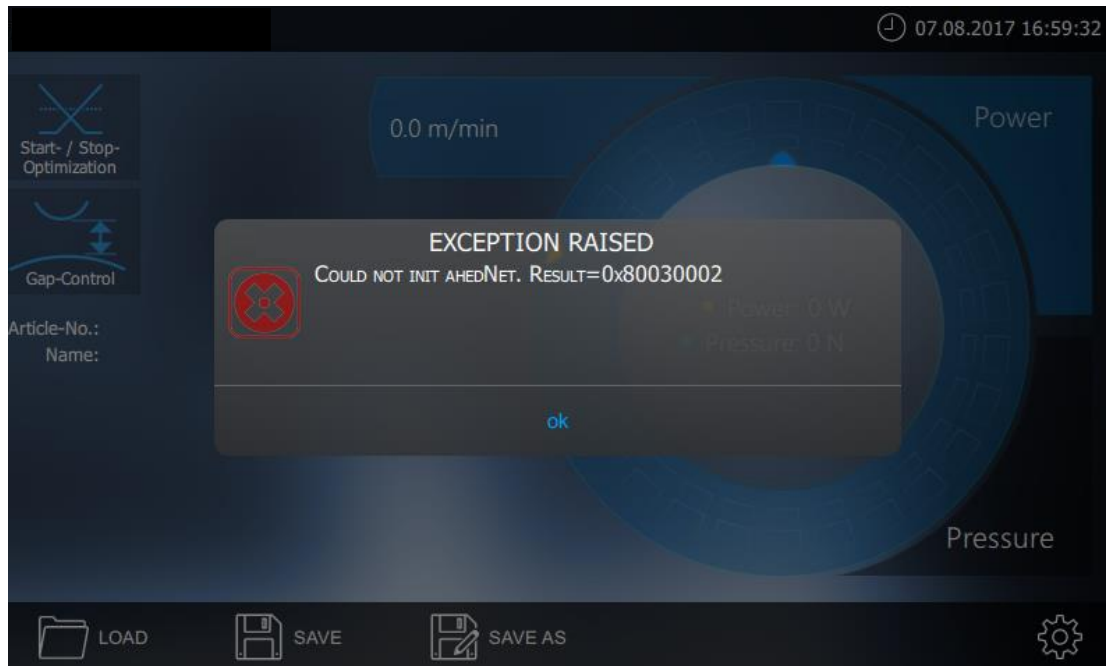

13 Welding



Only appropriately trained personnel should operate the machine. Operating personnel should also ensure that only authorized persons are positioned in the danger zone of the machine.

13.1 Welding principle

With the ultrasonic process the electrical vibrations generated by the ultrasonic generator are transformed into mechanical vibrations of the sonotrode.

Under the influence of pressure and temperature the material to be welded is heated. It is heated up to reaches the elastic-plastic threshold and is simultaneously transported.

To obtain an optimal welding result, certain prerequisites must be in place for the materials that will be processed.

The material that will be processed must

- Be weldable (thermoplast),
- Thickness and condition must be suitable for processing on the JEUX-7510,
- Should not have any contamination in the seam area.

The basic requirement on the machine side is

- Proper selection of the anvil wheel, as well as the
- Proper setting of:
 - contact pressure,
 - welding energy,
 - welding speed.

13.2 Determining welding parameters

To determine the correct welding parameters you must first decide between separation welding and pure overlap welding.

13.2.1 Welding

When welding there are basically three adjustable parameters - power (watt), contact pressure (display in % of maximum), and speed (m/min).

The greater the speed, the more power is required.

Power, in turn, is determined by 2 values – the set pressure and the amplitude, which is automatically regulated.

Automatic power control:

The JEUX-7510 series is factory-equipped with a real-time power control. This regulation makes it possible to compensate for mechanically and physically occasioned fluctuations in the application of welding energy between sonotrode and anvil wheel. In this process, constant power is realized by increasing or decreasing the amplitude. The prerequisite in this regard is that the amplitude must be in the control range of >50 % and <100 %, and not on minimum or maximum.

Example (fictive parameters):

Set values:

Power: 40 watt

Pressure: 2%

Speed: 3 m/min

If you now start the welding process you will note that actual power of only 20 watt is shown as an example ([link main menu and Analyser](#)) and the amplitude constant is on 100%.

Explanation:

The machine attempts to reach the set power of 40 watt (by increasing amplitude), however it does not reach this level because it is not possible to reach the desired welding power with the set pressure.

Solution:

Increase the pressure to a value at which the desired power can be achieved and the amplitude reaches the control range (optimally: amplitude between 60 % and 90 %).

Tip:

If you operate with a constant speed and do not use profiles, you can switch on automatic pressure correction, which automatically adapts the pressure as soon as it drops out of the control range.

If you want to work dynamically with different speeds, then you must create a profile in the Material Editor. This can be done manually ([link to Profile Editor](#)) or via the standard installed "wizard" ([here link to wizard](#)). In this regard through a function suitable power will then be set for each speed.

Depending on the material it may be the case that other welding results occur at the same power setting but different contact pressure (i.e. with more or less amplitude). This is primarily possible with extremely solid and strong materials, and the setting must be determined empirically.

13.2.2 Separation welding



The prerequisite in this case is that your JEUX-7510 must be fitted with a hardened cutting sonotrode or with the C|W package. If this is not the case then the sonotrode will be damaged and guarantee claim is void.



Only use JEUX C|W anvil wheels. If you use other anvil wheels the guarantee claim is void because damage to the sonotrode cannot be excluded.

With separation welding constant power is not necessary because power is only applied on a very thin stay.

Basically – depending on material thickness – you need relatively high contact pressure (>35 %) to separate the material.

Always start with low values and increase pressure and power step-by-step until you have reached your desired welding result. To protect the running surface of the cutting electrode, you should only use the minimum necessary contact pressure.